

Ford Data Interface 2019-Up

INTERFACE FEATURES

- Provides accessory power (12-volt 10-amp)
- Retains R.A.P. (Retained Accessory Power)
- Provides wires for multimedia radios (park brake, reverse, speed sense)
- Prewired AXSWC harness (AXSWC sold separately)
- Designed for non-amplified models*
- Retains balance and fade
- Micro-B USB updatable
- Retains factory backup camera on (Transit/Transit Connect Vehicles w/SYNC)

* AXAZB-FD1 required to retain OEM amplifier

NOTE: AXDI-FD3 does not retain SYNC

INTERFACE COMPONENTS

- AXDI-FD3 Interface
- AXDI-FD3 Harness

APPLICATIONS

Ford		
E Series	2021-Up	Escape
Eco Sport.....	2020-Up	F250/F350/F450/F550... 2020-Up
		Transit
		Transit Connect

Product Info



TABLE OF CONTENTS

Connections.....	2
Installation	3
Programming.....	3

TOOLS & INSTALLATION ACCESSORIES REQUIRED

- Crimping tool and connectors, or solder gun, solder, and heat shrink
- Tape
- Wire cutter
- Zip ties
- Multimeter tester

Visit AxxessInterfaces.com for more detailed information about the product and up-to-date vehicle specific applications.

ATTENTION: With the key out of the ignition, disconnect the negative battery terminal before installing this product. Ensure that all installation connections, especially the air bag indicator lights, are plugged in before reconnecting the battery or cycling the ignition to test this product. **NOTE:** Refer also to the instructions included with the aftermarket accessory before installing this device.

CONNECTIONS

From the AXDI-FD3 harness
to the aftermarket radio

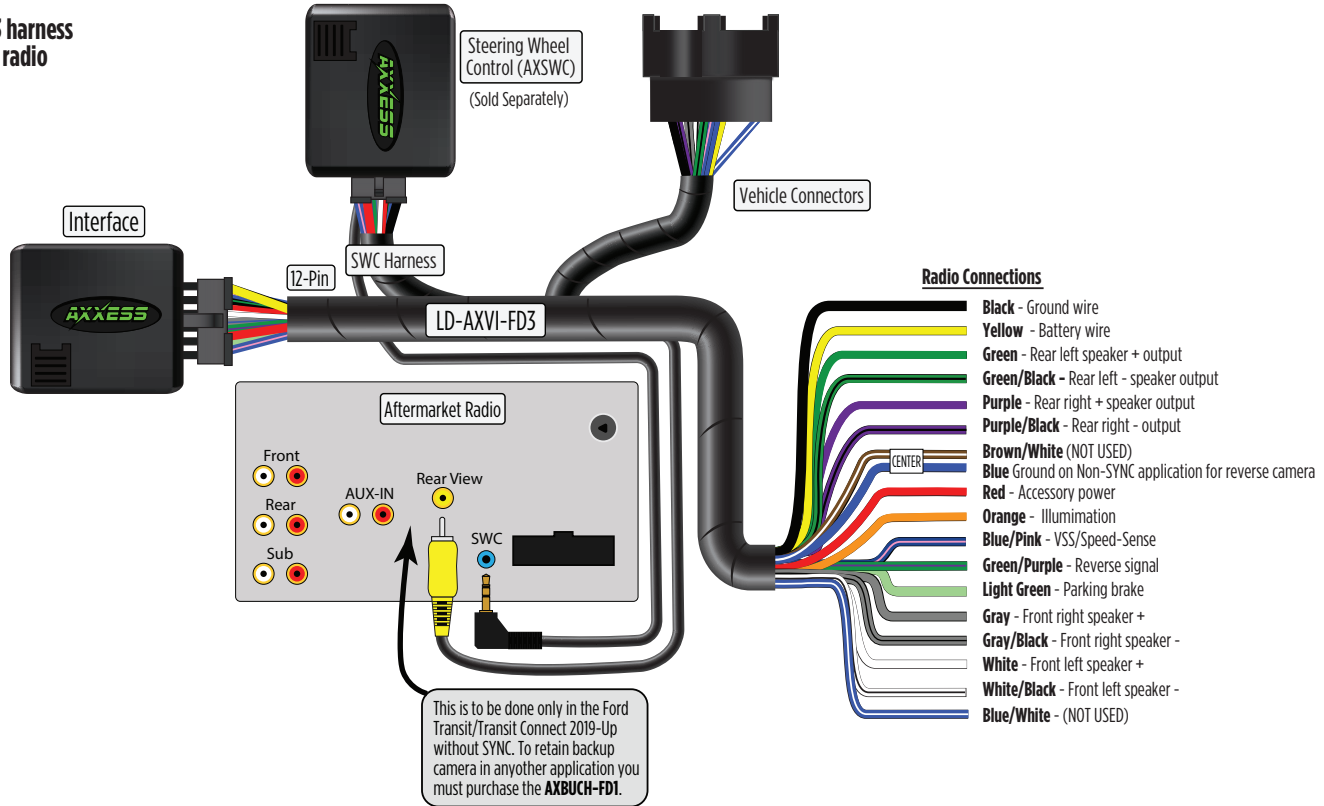

INSTALLATION

With the key in the off position:

1. Connect the **AXDI-FD3 harness** into the **AXDI-FD3 interface**, and then to the wiring harness in the vehicle.

Note: If installing an AXSWC, connect it after you program and test the AXDI-FD3, with the key in the off position.

PROGRAMMING

Attention! If the interface loses power for any reason, the following steps will need to be performed again.

1. Cycle the engine on.

Note: If the radio doesn't come on within 60 seconds, turn the key to the off position, disconnect the interface, check all connections, reconnect the interface, and then try again.

2. Cycle the ignition off, then back on.
3. Test all functions of the installation for proper operation.



AXDI-FD3

INSTALLATION INSTRUCTIONS

Having difficulties? We're here to help.



Contact our Tech Support line at:

386-257-1187



Or via email at:

techsupport@metra-autosound.com

Tech Support Hours (Eastern Standard Time)

Monday - Friday: 9:00 AM - 7:00 PM

Saturday: 10:00 AM - 5:00 PM

Sunday: 10:00 AM - 4:00 PM



KNOWLEDGE IS POWER

Enhance your installation and fabrication skills by enrolling in the most recognized and respected mobile electronics school in our industry. Log onto www.installerinstitute.edu or call 386-672-5771 for more information and take steps toward a better tomorrow.



**Metra recommends MECP
certified technicians**