



Land Rover Range Rover Vogue (with MOST25 amplifier) Data Interface with SWC 2002-2012

Visit AxxessInterfaces.com for more detailed information about the product and up-to-date vehicle specific applications

INTERFACE FEATURES

- Designed for MOST*25 amplified systems
- Provides accessory power (12-volt)
- Retains audio controls on the steering wheel controls
- Easy to set Dipswitches for SWC configuration
- Provides NAV outputs (parking brake, reverse, and speed sense)
- Micro B USB updatable

Note: Backup Camera not retained if equipped.

* Media Oriented System Transport

INTERFACE COMPONENTS

- AXDIS-LR82 harness
- AXDIS-LR82 interface
- MOST jumper harness
- SWC harness

APPLICATIONS

US Applications: Range Rover
Vogue (L322) 2005-2009

World Applications: Range Rover
Vogue (L322) 2002-2012

TABLE OF CONTENTS

Connections: BLK-AXDIS-LR82 harness.....	2
Applicable Radios.....	3
Steering Wheel Control Chart (SWC)	3
Installing the Fiber Optic Cable.....	4
Installing the AXDIS-LR82 interface	4

TOOLS REQUIRED

- Wire cutter
- Crimp tool and connectors
(example: butt-connectors, bell caps, etc.) or
- Solder gun, solder, heat shrink
- Tape • Zip-ties

ATTENTION: With the key out of the ignition, disconnect the negative battery terminal before installing this product. Ensure that all installation connections, especially the air bag indicator lights, are plugged in before reconnecting the battery or cycling the ignition to test this product.

NOTE: Refer also to the instructions included with the aftermarket radio.

CONNECTIONS: BLK-AXDIS-LR82 HARNESS

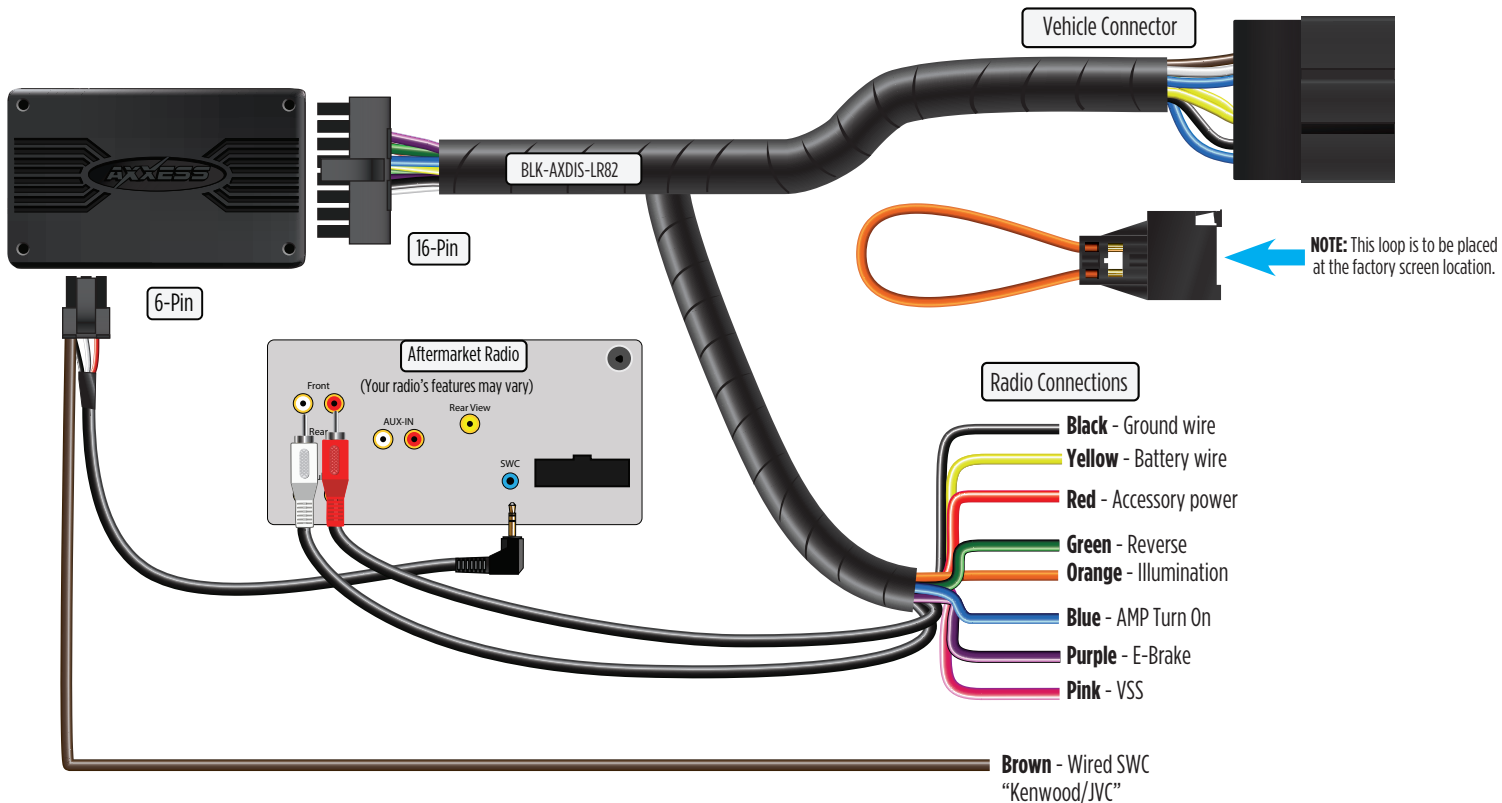

APPLICABLE RADIOS

Alpine Premium Sound Systems: 05-09 Radio W/NAV

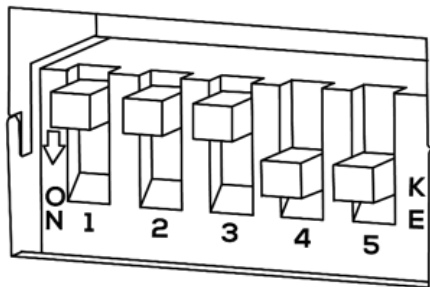

Press dipswitch in to the down position to turn ON.
Pioneer 1 example shown in the diagram.

SWC CHART

Metra MOST Interface Dipswitch Table

MFR	System	DIP Switch Settings					Additional Comments
		1	2	3	4	5	
RESERVED	NA	OFF	OFF	OFF	OFF	OFF	SW UPDATE MODE
ALPINE	IR DATA	OFF	ON	OFF	OFF	OFF	
AXXERA 2	IR DATA	ON	ON	OFF	OFF	OFF	
CLARION 1	IR DATA	ON	OFF	OFF	ON	OFF	
CLARION 2	IR DATA	ON	ON	OFF	ON	OFF	
DUAL	Analog	OFF	OFF	ON	ON	OFF	
GRUNDIG	IR DATA	OFF	ON	OFF	ON	OFF	
JENSEN	Analog	OFF	OFF	OFF	ON	ON	
JVC	IR DATA	OFF	OFF	ON	OFF	OFF	BROWN WIRED SWC
KENWOOD 1	IR DATA	ON	OFF	OFF	OFF	OFF	BROWN WIRED SWC
KENWOOD 2	IR DATA	ON	ON	OFF	OFF	OFF	BROWN WIRED SWC
LG 1	Analog	OFF	OFF	ON	ON	OFF	
LG 2	IR DATA	OFF	ON	ON	OFF	OFF	
PHILIPS 1	IR DATA	ON	OFF	ON	ON	OFF	
PHILIPS 2	IR DATA	OFF	ON	OFF	ON	OFF	
PIONEER 1	Analog	OFF	OFF	OFF	ON	ON	MALE 3.5MM JACK
PIONEER 2	Analog	OFF	OFF	OFF	ON	OFF	MALE 3.5MM JACK
SONY	Analog	OFF	OFF	ON	ON	OFF	MALE 3.5MM JACK
VALOR	IR DATA	ON	OFF	ON	OFF	OFF	
SPARE	IR DATA	OFF	ON	ON	ON	OFF	
SPARE	Analog	ON	ON	ON	OFF	OFF	
SPARE	Analog	ON	ON	ON	ON	OFF	

INSTALLING THE FIBER OPTIC CABLE

Installing the Fiber Optic Cable:

Removal of the original fiber optic connection is required to adapt to the **Media Oriented System Transport (MOST)** interface.

- Seat the **AXDIS-LR82** amplifier interface in the black connector housing provided with this kit and snap the housing in place. (Figure A)
- From the original **Fiber Optic Connector**: Using a pick tool, carefully pull this tab towards the outside edge for the connector housing. Gently remove the fiber optic insert from the connector. (Figure B)
- From the **MOST Interface**: Push the tab toward the gray dust cover and, using a needle nose plier, remove the gray dust cover. Replace the gray connector with the factory fiber optic cables into the MOST interface's black connector housing. (Figure C)



(Figure A)

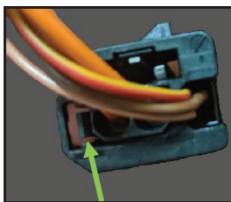

(Figure B)

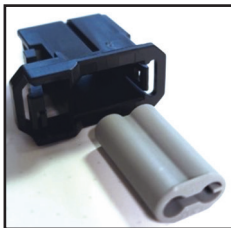

(Figure C)

INSTALLING THE AXDIS-LR82 INTERFACE

With the key in the off position:

1. Connect **male 3.5mm jack** to the steering wheel control port on the radio.
2. Ensure that the dipswitches are set to the desired radio type. Refer to **SWC Chart** on page 3.
3. Connect the **AXDIS-LR82 harness** to the **AXDIS-LR82 interface**.
4. Remove the **dust cover** from the optic port on the **AXDIS-LR82 interface**.
5. Connect the factory **fiber optic cable** to the **AXDIS-LR82 interface**.
6. Connect the **AXDIS-LR82 harness** to the **wiring harness** in the vehicle.
7. Turn on the ignition and test all features.

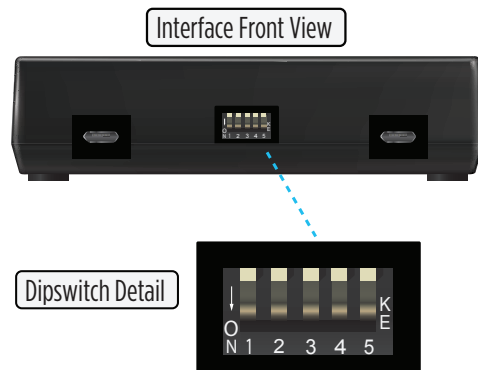

NOTE: For Dipswitch Settings for your Radio Type, refer to **SWC Chart** on page 3.







Lined writing area consisting of two columns of horizontal lines for notes.



AXDIS-LR82

INSTALLATION INSTRUCTIONS



Having difficulties? We're here to help.



Contact our Tech Support line at:

386-257-1187



Or via email at:

techsupport@metra-autosound.com

Tech Support Hours (Eastern Standard Time)

Monday - Friday: 9:00 AM - 7:00 PM

Saturday: 10:00 AM - 5:00 PM

Sunday: 10:00 AM - 4:00 PM



**Metra recommends MECP
certified technicians**