



[www.MetraOnline.com](http://www.MetraOnline.com)

For **Dash Disassembly Instructions**, refer to [metraonline.com](http://metraonline.com). Enter the year, make, and model of the vehicle in the **Vehicle Fit Guide** for **Radio Install kits**.



## DSP Interface With Pre-Wired Harness

### Fits GM 2007-2017

#### INTERFACE FEATURES

- Designed for both amplified and non-amplified models
- Includes a DSP (Digital Signal Processor)
- 31 Band graphic EQ
- 10 individually assignable outputs
- Independent equalization on each of the 10 outputs
- Independent high pass, low pass, and bandpass filters
- Each channel can be delayed independently up to 10ms
- Clipping detection and limiting circuits
- Retains factory parking sensor chimes

*(Features continued on next page)*

#### Google Play Store

Android 9 or higher



#### Apple App Store

iOS 12.1 or higher



#### APPLICATIONS

Visit [axxessinterfaces.com](http://axxessinterfaces.com) for current application list

#### TABLE OF CONTENTS

Installation & Installation Options.....	2
Connections.....	3-4
Mobile App.....	5-6
Specifications.....	7

#### INTERFACE COMPONENTS

- AXDSPX-GL1 interface
- AXDSPX-GL1 interface harness
- AXDSPX-GL1 vehicle T-harness • Bass knob

#### TOOLS & INSTALLATION ACCESSORIES REQUIRED

- Crimping tool and connectors, or solder gun, solder, and heat shrink • Tape • Wire cutter
- Zip ties • Multimeter

**ATTENTION:** With the key out of the ignition, disconnect the negative battery terminal before installing this product. Ensure that all installation connections, especially the air bag indicator lights, are plugged in before reconnecting the battery or cycling the ignition to test this product.

**NOTE:** Refer also to the instructions included with the aftermarket accessory before installing this device.

## INSTALLATION OPTIONS

### Adding a subwoofer to a factory system:

This feature offers the ability to add a subwoofer to a factory system, whether amplified or non-amplified. (refer to **page 3**)

### Adding a full-range amp & sub to a factory system:

This feature offers the ability to add a full-range amp and sub to a factory system, whether amplified\* or non-amplified. (refer to **page 4**)

\* For amplified models the amp must be bypassed/unplugged, and **With OE Amplifier** chosen in the **Configuration** tab under **Vehicle Type**.

**Note:** The interface provides a 12-volt 1-amp output to turn on aftermarket amp(s). If installing multiple amps, an SPDT automotive relay will be required if the amp turn-on current of all amps combined exceeds 1-amp. Use Metra part number E-123 (sold separately) for best results.

## FEATURES CONT.

- Retains OnStar® voice prompts
- Adjustable chime level
- Easy behind the radio installation with pre-wired harness
- Bass knob included for level control of subwoofer amp
- Settings adjusted via Bluetooth® in a smart device application (tablet or mobile phone), compatible with both Android and Apple devices
- Read, write, and store configurations for future recall
- Password protect feature available in the mobile app
- Micro-B USB updatable

## INSTALLATION

1. Remove the factory radio\*, then unplug all connectors.
2. Install the **AX-DSPX-GL1 vehicle T-harness** to the vehicle and make all necessary connections, but leave the amp turn-on wire disconnected.
3. Plug the **AX-DSPX-GL1 vehicle T-harness** to the **AX-DSPX-GL1 interface**.
4. Plug the **AX-DSPX-GL1 interface harness** to the **AX-DSPX-GL1 interface**.
5. Download and install the AXDSP-X app from the **Google Play Store** or **Apple App Store**.
6. Open the app then select the **Bluetooth® Connection** tab. Follow the instructions to pair the mobile device to the interface. Refer to **page 6** for more information.
7. Scroll to the **Configuration** tab then select the vehicle type. Press the **Lock Down\*\*** button to save the configuration. Refer to **page 7** for more information.
8. Connect the amp turn-on wire.
9. Adjust the settings in the app as desired. Press the **Lock Down\*\*** button to save any new configurations.

\* For dash disassembly instructions, refer to **metraonline.com**. Enter the year, make, and model of the vehicle in the **Vehicle Fit Guide** and find instructions under **Metra Radio Install** kits.

\*\* Anytime the interface is locked down the key must be cycled off then back on

# ADDING A SUB TO A FACTORY SYSTEM

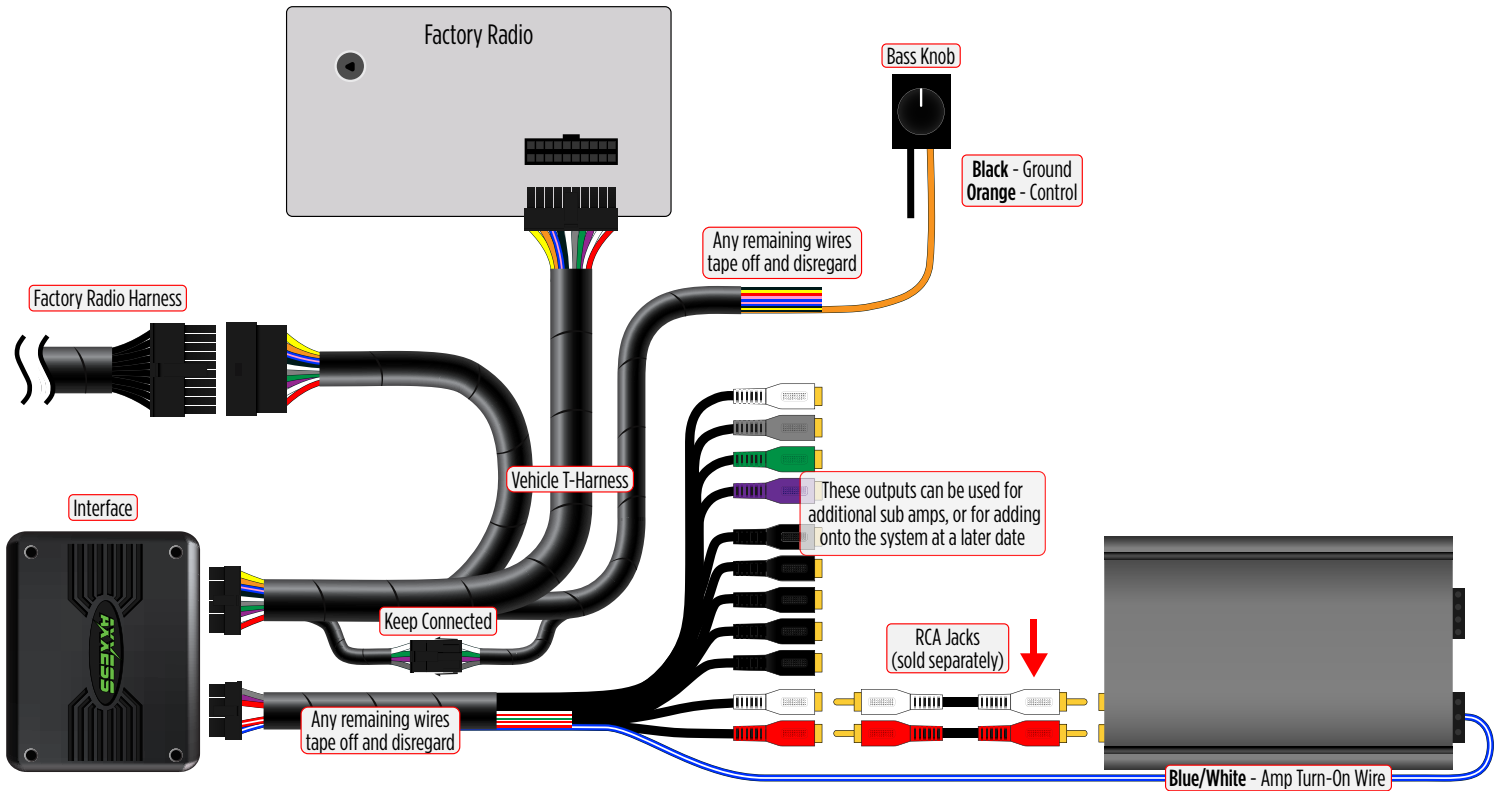

## ADDING A FULL-RANGE AMP & SUB TO A FACTORY SYSTEM

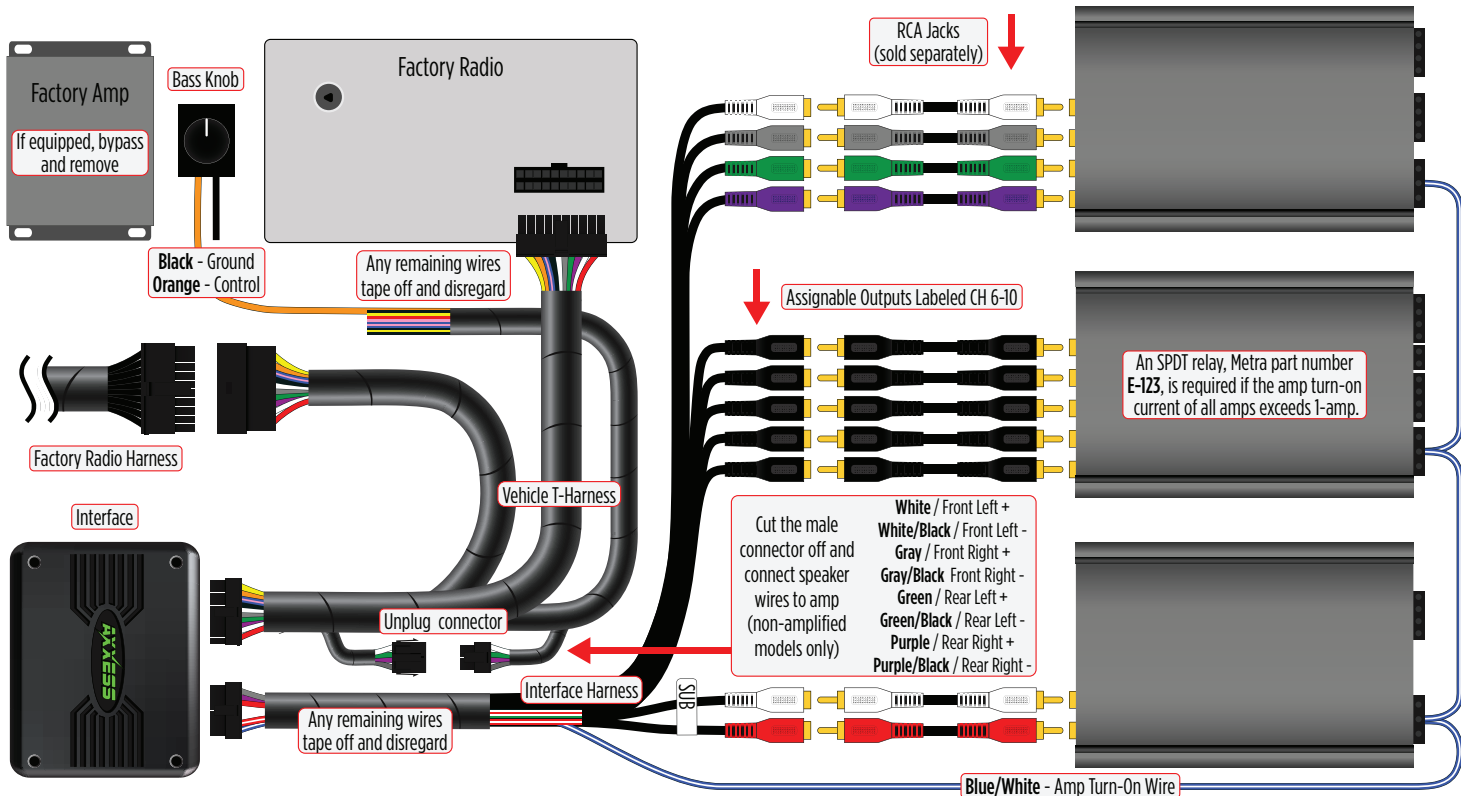

## MOBILE APP: QUICK SETUP STEPS THROUGH AXDSP-XL APP

Google Play Store  
Android 9 or higher



Apple App Store  
iOS 12.1 or higher



1. Download and install the **AXDSP-XL App** from the **Google Play Store** or **Apple App Store**.
2. Turn Vehicle Ignition on. Make sure the Remote Turn On lead is disconnected.
3. Open the app: Select **Bluetooth® Connections** page.
  - Select **Scan**, all available AXDSP devices within range will be displayed. Select your AXDSP and hit connect. (Figure A)
4. Select the Configuration page.
  - Select **Vehicle Type** Icon
  - Select the Vehicle Make: \_\_\_\_\_ (Example: **GMC**)
  - Select the Vehicle's model: \_\_\_\_\_ (Example: **SIERRA**)
  - Select **With OE Amp** or **Without OE Amp**
  - Hit **Apply** (Figure B)
5. Make sure radio volume is all the way down.
6. Connect the amp turn-on wire from the **AXDSPX-GL1 T-harness** to the aftermarket amplifiers.

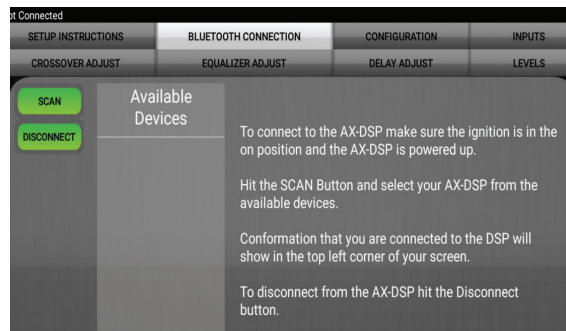

(Figure A)

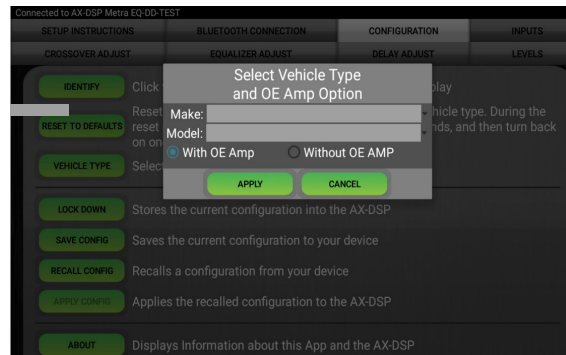

(Figure B)

- From the **Configuration** page click the **Identify** button to confirm that the **AXDSPX-GL1** is connected properly. If so, a chime will be heard from the front left speaker.
- Press the **Lock Down** button to save the configuration. (Do not turn ignition off until this process is completed) (Figure C)
- Select the **Bluetooth® Configurations** page and disconnect the DSPX.
- Turn ignition off, close all doors, then lock vehicle using the key fob. The vehicle will need to sit uninterrupted for 10 minutes while the vehicle goes to sleep. (Make sure Key fob is 15 feet away from the vehicle)
- Unlock Vehicle, turn ignition on and test radio's functions.
- Adjust the DSP settings in the app as desired. Refer to the instructions under the **Setup Instructions** tab, or online at [Axxessinterfaces.com](http://Axxessinterfaces.com) for an explanation of each tab in the app.

### Locking Down Data

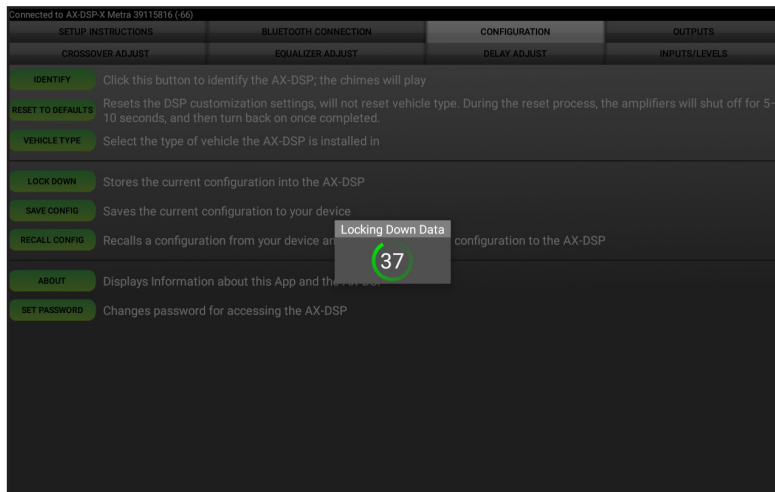

(Figure C)

**Last and the most important:  
You MUST lock down your  
configuration and cycle the key!!!**

## SPECIFICATIONS

Input Impedance	1M Ohm	Operating Voltage	10-16 volts DC
Input Channels	6	Standby Current Draw	7mA
Input Options	High Level or Low Level	Operation Current Draw	150mA
Input Type	Differential balanced	Adjustments/Controls	Application via Bluetooth
Input Voltage	0 - 28-volts (peak-to-peak)	Remote Output	12 volts DC (signal sense or with ignition)
(high level range)			
Input Voltage	0 - 4.9-volts (peak-to-peak)		
(low level range)			
Output Channels	10		
Output Voltage	Up to 5-volts RMS		
Output Impedance	50 Ohms		
Equalizer Type	31 Band Graphic EQ, +/- 10dB		
THD	<0.03%		
Frequency Response	20Hz - 20kHz		
Crossover	3-Way LPF, BPF, HPF THP per channel		
Crossover Type	Linkwitz-Riley 24db slope		
Sampling	48kHz		
S/N Ratio	105dB @ 5-volts RMS		



# AXDSPX-GL1

INSTALLATION INSTRUCTIONS



Further troubleshooting steps and information can be located at:

[axxessinterfaces.com/product/AXDSPX-GL1](https://axxessinterfaces.com/product/AXDSPX-GL1)

Having difficulties? We're here to help.



Contact our Tech Support line at:

**386-257-1187**



Or via email at:

[techsupport@metra-autosound.com](mailto:techsupport@metra-autosound.com)

### Tech Support Hours (Eastern Standard Time)

Monday - Friday: 9:00 AM - 7:00 PM

Saturday: 10:00 AM - 5:00 PM

Sunday: 10:00 AM - 4:00 PM



**Metra recommends MECP  
certified technicians**