

Steering Wheel Control & Data Interface Fits Ford **Select Models 2014-2019**

Visit AxxessInterfaces.com for more detailed information about the product and up-to-date vehicle specific applications.

INTERFACE FEATURES

- Designed for amplified and non-amplified models
- Provides accessory power (12-volt 10-amp)
- Provides wires for multimedia radios (park brake, reverse, speed sense)
- Retains audio controls on the steering wheel
- Designed to be compatible with all major radio brands
- Auto detects vehicle type, radio connection, and preset controls
- Ability to dual assign steering wheel control buttons
- Retains memory settings even after battery disconnection or interface removal (non volatile memory)
- Provides illumination output
- Retains the 3.5mm AUX-IN jack
- USB Micro-B updatable
- Retains factory backup camera

APPLICATIONS

Ford

Escape	2015-2019
Fiesta	2014-2019
Focus	2015-2018
Transit full size van	2014-2019

TABLE OF CONTENTS

Connections.....	2
Programming.....	3
Troubleshooting.....	4

INTERFACE COMPONENTS

- AXTC-FOC interface
- LD-SWCX-FOC harness
- 3.5mm adapter
- LD-FD54SWC
- LD-FD12SWC
- Amplifier step-down

TOOLS & INSTALLATION ACCESSORIES REQUIRED

- Crimping tool and connectors, or solder gun, solder, and heat shrink • Tape • Wire cutter • Zip-ties

ATTENTION: With the key out of the ignition, disconnect the negative battery terminal before installing this product. Ensure that all installation connections, especially the air bag indicator lights, are plugged in before reconnecting the battery or cycling the ignition to test this product.

NOTE: Refer also to the instructions included with the aftermarket accessory before installing this device.

Product Info



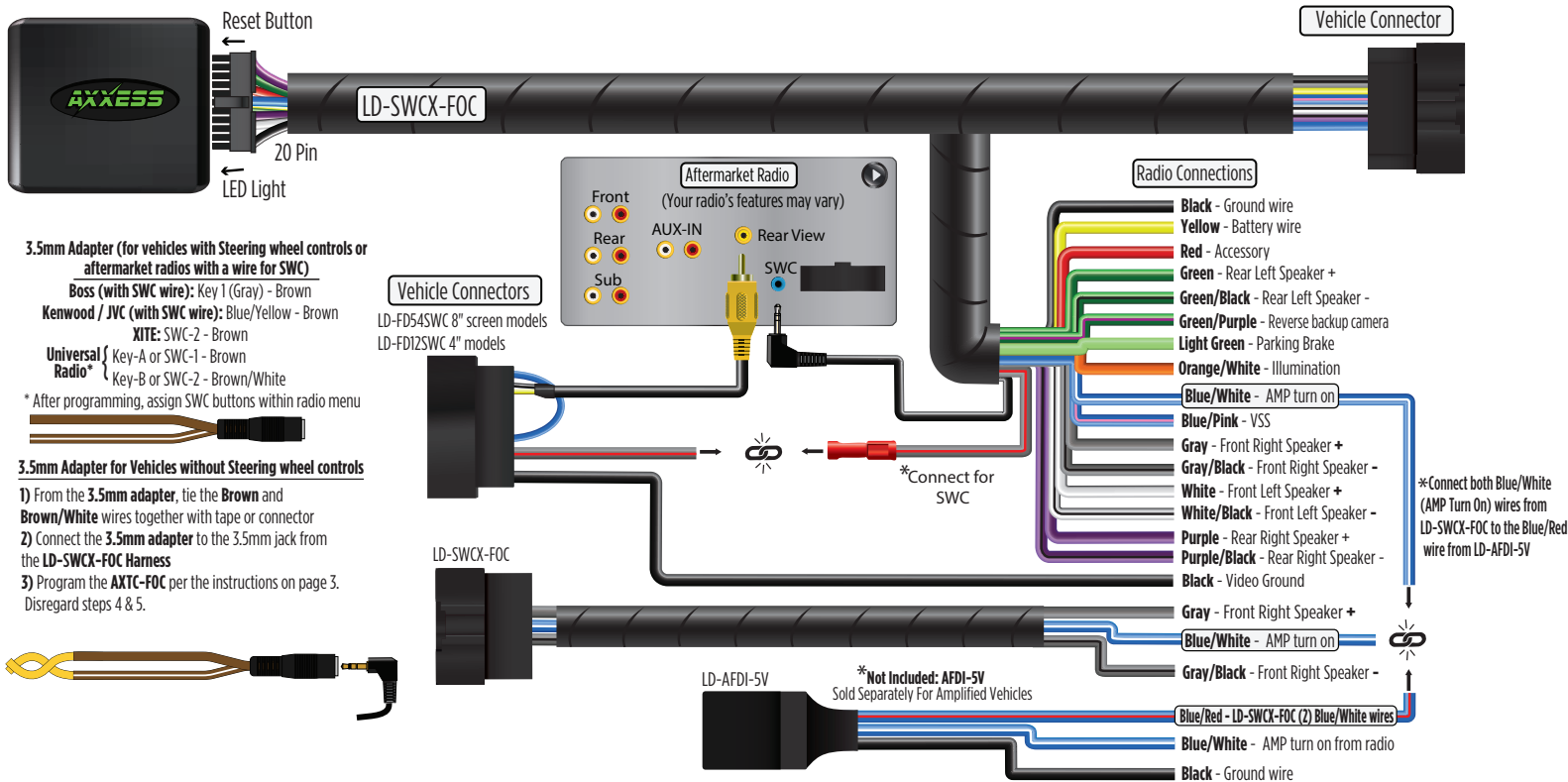

CONNECTIONS: LD-SWCX-FOC



PROGRAMMING

- 

1. Open the driver's door, and keep open during the programming process.
- 

2. Cycle the ignition on and wait (5) seconds, or until the factory display screens reads **LINE IN**.
- 

3. Connect the **LD-SWCX-FOC harness** to the **AXTC-FOC interface**, and then to the wiring harness in the vehicle.
- 

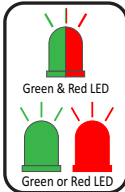
4.* **For (auto*) vehicles:** Do not touch the steering wheel controls, the interface will auto program.
*Only applicable if vehicle came with steering wheel controls
- 

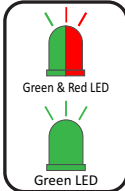
5. The LED light will flash **Green & Red** while the interface programs the radio to the steering wheel controls. Once programmed, the LED light will go out, then produce a pattern which will identify the radio type installed.
*Only applicable if vehicle came with steering wheel controls
- 

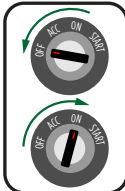
6. The LED light will go out, then once again quickly flash **Green & Red** while the interface programs itself to the vehicle. Once programmed, the LED light will go out again, then turn solid **Green**.
- 

7. Cycle the ignition off, then back on.
- 

8. Test all functions of the installation for proper operation.

TROUBLESHOOTING

1.

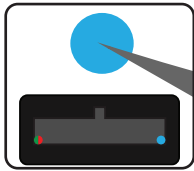

LED Light Reset Button

If the interface fails to function, press and release the Reset Button, then repeat the programming process from step 4 to try again.

2.

Final LED Feedback

At the end of programming the LED light will turn **Solid Green** which indicates programming was successful. If the LED light didn't turn **Solid Green**, reference the list below to understand which programming section the problem may stem from.

LED Light	Radio Programming Section	Vehicle Programming Section
Solid Green	Pass	Pass
Slow Red Flash	Fail	Pass
Slow Green Flash	Pass	Fail
Solid Red	Fail	Fail

Note: If the LED light shows **Solid Green** for **Pass** (indicating everything programmed correctly), yet the steering wheel controls don't work, check to ensure that the 3.5mm jack is plugged in, and also plugged into the correct jack on the radio. Once corrected, press the reset button, then program again.

QR Code Scan Here



Further troubleshooting steps and information can be located at: axessinterfaces.com

Having difficulties? We're here to help.



Contact our Tech Support line at:
386-257-1187



Or via email at:
techsupport@metra-autosound.com

Tech Support Hours (Eastern Standard Time)

Monday - Friday: 9:00 AM - 7:00 PM

Saturday: 10:00 AM - 5:00 PM

Sunday: 10:00 AM - 4:00 PM

**Metra recommends MECP
certified technicians**