

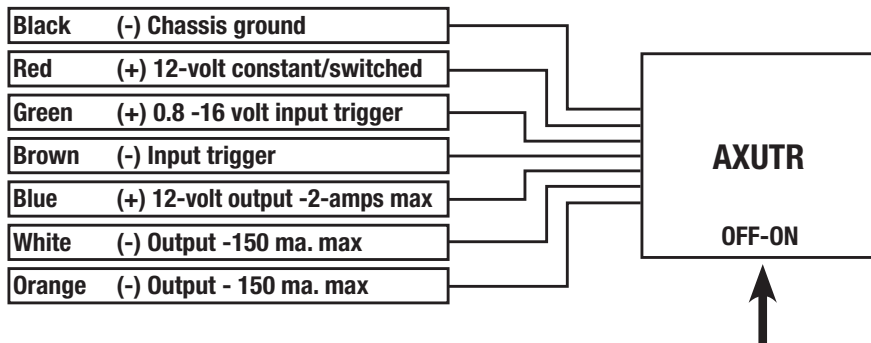

## Installation instructions for part AXUTR

### AXUTR



Programming switch must be turned off after the AXUTR is programmed!

### KIT FEATURES

The AXUTR is a universal trigger output module that has various user programmable features combined into one unit. The user programmable features are stored in non-volatile memory. When triggered, the AXUTR can turn on the outputs as a pulsed, latched or timed.

### TABLE OF CONTENTS

Features .....	2-4
- Feature Chart.....	4
Wiring Instructions .....	5-6
Programming the AXUTR.....	7-8

**CAUTION!** All accessories, switches, climate controls panels, and especially air bag indicator lights must be connected before cycling the ignition. Also, do not remove the factory radio with the key in the on position, or while the vehicle is running.



## Features

### Basic Description of Features:

There are two inputs, the **GREEN** wire is a positive input that senses voltages as low as 0.8-volt and the **BROWN** wire is a negative input, both are tied together internally which is, essentially, ONE trigger input. There are 3 separate outputs; the **BLUE** wire is a positive 12-volt output which has a maximum current rating of 2-amps. The **WHITE** and **ORANGE** wires are negative outputs which have a maximum of current rating of 150-milliamps. The timed output is user adjustable and can be programmed up to 4 minutes and 15 seconds. What makes the AXUTR unique is that it does not use a potentiometer to adjust the timer. The timer is set by programming AXUTR minutes and seconds with a number. The time saved is accurate to the second +7% - 8%.

The basic descriptions below are the features that can be done with the AXUTR. Each feature is assigned Feature#. Please make note of which Feature# you are going to use. Other unique projects/installs can also be derived from the AXUTR, so AXXESS leaves it to the installer's imagination to experiment with these features.

#### #1 - Low voltage trigger:

Supplies a 12-volt remote output for an aftermarket amplifier when used with a stock head unit that does not have a remote output. Use the AXUTR to supply a 12-volt output from a 5-volt remote source, like from Ford radios. Use on some vehicles that have a negative antenna output and convert to a positive output.

#### #2 - Alpine video bypass:

This will automatically bypass Alpine's flip out monitor video procedure. **WARNING!** It is dangerous (and illegal in most states) for the driver to watch the TV/Video monitor while driving the vehicle. The driver may be distracted from looking ahead and an accident could occur. Install the AXUTR only in RV and Marine applications where there is no parking/hand brake to interface to. Do not install the AXUTR where the driver may be able to view the monitor when driving.

#### #3 - Latch and unlatch output from a pulsed input:

Turn on headlights, neon lights or radio from an alarm with a momentary output or from a momentary switch.

#### #4 - Double pulse output:

Pulses outputs twice when trigger from a constant or pulsed signal. Use for alarm applications where the unlock wire needs 2 pulses to unlock all doors.

#### #5 - Closed loop circuit:

Good for monitoring trailers on hitches by triggering an aftermarket alarm if the trailer is disconnected from the vehicles hitch. Also monitors stereo equipment in vehicles.

#### #6 - Pulse extender/Delayed turnoff:

Upon a constant or pulsed trigger, the AXUTR will turn on the outputs. As soon as the trigger is disconnected, turned off or at the end of a pulse, the timer will count up to the number of seconds recorded, at which time the outputs will turn off. Good for turning on headlights at night for convenience. Extend alarms output from 1 second to 3 seconds for Mercedes vacuum door locks. (rev.2)

#### #7 - Horn honking output:

On older, aftermarket alarms, it may have been difficult to disarm the alarm with the RF remote when the horn was honking. This will give you a 2 second delay between honks, allowing you to disarm the alarm. Unique horn honking to distinguish your vehicle from others. Program between 1 and 5 honks before the 2 second delay.

*Continued on the next page*



## Features *(Continued)*

### **#8 - Linear Actuator Controller:**

Open/close amplifier racks from a momentary source like from a alarm's negative output. Sequence is: Start, Stop, Reverse, and Stop.

### **#9 - Door lock Pulse generator:**

Good for automatically locking and unlocking door locks when ignition is turned on and off.

### **#10 - Channel Splitter:**

Split 1 channel from an alarm to 2 outputs. Both outputs are user programmable for pulse, latched or timed output.

### **#11 - Pulses to constant output:**

Counts a number of user programmable pulses within a user programmed time to turn on the outputs. Good for triggering Vehicle tracking devices that need a constant trigger but the factory alarm only has a pulsed output when triggered like flashing lights or horn honking. Keeps factory alarm from triggering Vehicle tracking device when arming or disarming.

### **#12 - 3 timers in 1:**

Upon a constant trigger, all 3 outputs are user programmable to delay before turning on outputs or turning on instantly then delay before turning off outputs. Good for situations where you need more than 1 timer but on a different timer period, without having multiple modules.

### **#13 - Pulses to latch/unlatch outputs:**

Upon a number of pulses within a user programmable time, the outputs will latch. Upon a number of pulses within a user programmable time the second time, the outputs will unlatch. You may program how many pulses to latch and unlatch. Use to turn on aftermarket driving lights by using existing parking light switch.

### **#14 - Pulses to pulse output:**

Upon number of pulses within a user programmable time, the outputs will pulse. **Example:** if you programmed to see 4 pulses, for every 4 pulses the AXUTR sees within a 5 second time period, the outputs will pulse once.

### **#15 - Pulses to timed output:**

Upon a number of pulses within 5 seconds, the outputs will turn on and delay for the amount of programmed time, then the outputs will turn off.

### **#16 - Latching outputs #2:**

Good for turning on 2 sets of driving lights with one momentary switch. 1st pulse will latch one wire. 2nd pulse will unlatch first wire and latch second wire. 3rd pulse will latch both wires. 4th pulse turns off both wires.

## Features (Continued)

Feature	Feature#	Feature Select			Timer			Outputs used			
		Blue	White	Orange	Blue	White	Orange	Blue (+)	White (-)	Orange (-)	
Low voltage trigger	1							M			
Alpine video bypass (factory default)	2							M			
Latching on / off outputs	3							M			
Double pulse	4							M			
Closed loop trigger	5					T		M			
Pulse extender	6					T		M			
Horn honk	7	count number of pulses to pulse output						M			
Linear actuator controller	8							x	x	x	
Doorlock pulse generator	9				unlock = 1, no unlock = 2				x	x	
Channel splitter	10		pulse = 1, latch = 2, timer = 3	pulse = 1, latch = 2, timer = 3		T	T		x	x	
Number of pulses for constant output	11	count number of pulses for trigger				T			M		
3 programmable timer outputs on constant trigger	12	delayed on = 1, delayed off = 2	delayed on = 1, delayed off = 2	delayed on = 1, delayed off = 2		T	T	T	x	x	x
Number of pulses to latch / unlatch output	13	1. Count # of pulses to latch output 2. Count # of pulses to un-latch output				T			M		
Number of pulses to pulse output	14	count number of pulses to pulse output				T			M		
Number of pulses for timer output	15	count number of pulses for timer output				T			M		
Latching outputs #2	16								x	x	

*M = Married wires. Both wires either pulse, latch/unlatch or time at the same time. T = Timer. Indicated wires must be programmed with a time.*



## Wiring Instructions

1. Connect the **BLACK** wire to chassis ground.
2. Connect the **RED** wire to switched 12-volt. (After programming, the **RED** wire can be left on switched or wired to constant 12-volt)
3. Go to Page 7 and program the AXUTR with the selected Feature# you need.

### Return here to finish wiring the AXUTR.

4. Connect the **BLUE**, **WHITE** and **ORANGE** wires to relays as indicated below for the selected Feature#. Do not connect the **BLUE**, **WHITE** or **ORANGE** wires to devices directly unless instructed.
5. Always use a fuse when using relays with a 12-volt source!

**#1: On a constant trigger:** both the **BLUE** and **WHITE** wire will activate after a one second delay. If you are using the AXUTR to turn on an amplifier, you can connect the **GREEN** wire to any (+) speaker wire lead and the **BLUE** wire to the amplifier's remote input. If you need to invert a negative to a positive output, connect the **BROWN** wire to the source and the **BLUE** wire to the device that needs to see a positive signal to activate. The **BLUE** wire can connect directly to 1 to 4 devices that have a remote trigger input. If the total current draw of the devices exceeds 2-amps, use a relay to supply 12-volt at a higher current.

**#2: This will automatically bypass Alpine's video procedure:** After programming (detailed programming on page 7), connect the **GREEN** wire to the Alpine's remote wire, the **BLUE** wire to the Alpine's foot brake input wire, the **WHITE** wire to the Alpine's parking brake input wire. In this configuration, relays are not needed. Do not connect any other sources to the **WHITE** or **BLUE** wires of the AXUTR. Connect the **RED** wire to vehicle's accessory 12-volt. Note: This feature is factory set. Keep switch to off position and wire according to above. No programming is necessary unless changed.

**WARNING!** *It is dangerous (and illegal in most states) for the driver to watch the TV/Video monitor while driving the vehicle. The driver may be distracted from*

*looking ahead and an accident could occur. Install the AXUTR only in RV and Marine applications where there is no parking/hand brake to interface to. Do not install the AXUTR where the driver may be able to view the monitor when driving.*

**#3:** Connect the **BROWN** or **GREEN** wire to a momentary source, like from a switch or alarm's output. When triggered, the **BLUE** and **WHITE** wire will turn on and stay on. When triggered a second time, the **BLUE** and **WHITE** wires will turn off. Use the **BLUE** or **WHITE** wire to activate a relay to turn on lights, neon, or any other source that draws high current.

**#4:** Connect the **BROWN** wire to the alarm's unlock output and connect the **BLUE** wire or **WHITE** wire to the unlock wire of the vehicle that needs to see 2 pulses to unlock all doors.

**#5:** Extend the **BROWN** wire and connect to the chassis of the trailer or the back of stereo in such a way that the **BROWN** wire must be cut or disconnected from the chassis, if a theft is in progress. The **BROWN** wire must be connected to a good chassis source so that it will not false trigger. Connect the **BLUE** or **WHITE** wire to an alarm or other alarming device trigger input. You may program a delayed time before the outputs will turn on when the **BROWN** wire is disconnect from the chassis.

**#6:** Connect the **BROWN** or **GREEN** wire to a pulsed or constant source. Connect the **BLUE** or **WHITE** wire to the device that you want to activate for a time period. You may program a delayed off time. The delay will not start until the end of the pulse or when the constant trigger is off.

**#7:** Connect the **BROWN** or **GREEN** wire to the siren output of the alarm. Connect the **BLUE** or **WHITE** wire to a relay that will supply a positive or negative output to the horn wire. When triggered, the AXUTR will delay 2 seconds before honking the horn.

**#8:** Although this is not a full Linear Actuator Controller (does not have a brake wire), the AXUTR will brake correctly when used with limit switches. If wired according to the diagram on the diagram page, the linear actuator will function and work correctly.

*Continued on the next page*



## Wiring Instructions *(Continued)*

Connect the **BROWN** or **GREEN** wire to a momentary source. When pulsed the first time the **WHITE** wire will latch on, then 1.5 seconds later the **BLUE** wire will latch on (this will allow time for the limit switches to turn off) . On a second pulse both the **BLUE** and **WHITE** wire will turn off. On a 3rd pulse the **ORANGE** wire will latch on, then 1 second later the **BLUE** wire will latch on.

**#9:** Connect the **GREEN** wire to a true ignition wire of the vehicle. Connect the **WHITE** wire to the lock relay and the **ORANGE** to the unlock relay. When the ignition is turned on, the **WHITE** wire will pulse once after a 5 second delay. When the ignition is turned off, the **ORANGE** wire will pulse once. The **ORANGE** wire is user programmable not to pulse when the trigger is disconnected.

**#10:** Connect the **BROWN** wire to the alarm's negative output. Connect the **WHITE** wire to the first device being controlled and the **ORANGE** wire to the second device being controlled. Use relays if the devices draw more than 150-milliamps. After a single pulse from the alarm within 3 seconds, the **WHITE** wire will activate. After two pulses within 3 seconds, the **ORANGE** wire will activate. Each wire is user programmable for a pulse, latch or a timed output. Please note that if any one of the two wires are programmed for a timer output, the AXUTR will not respond until the timer is finished.

**#11:** Connect the **GREEN** or **BROWN** wire to the factory alarm's flashing light or horn output. Connect the **BLUE** or **WHITE** wire to the vehicle tracking device trigger input. You can program the amount of pulses the AXUTR sees within a user programmable number of seconds to trigger the vehicle tracking device.

**Example:** if the factory alarm flashes or honks the horn a maximum of 2 times when arming or disarming, then you may program the AXUTR to see a minimum of 4 pulses within a 5 second period to trigger the AXUTR which will turn on the **BLUE** and **WHITE** wire. As long as the pulses continue, the AXUTR **BLUE** or **WHITE** wire will stay on.

**#12:** Connect the **BROWN** or **GREEN** wire to a source that stays constant when turned on. Connect the **BLUE**, **WHITE** and **ORANGE** wire to the devices being

controlled. Both outputs are user programmable to delay before turning on the outputs or programmable to turn on outputs instantly, then delaying before turning off. You do not need to use all the outputs, but during programming you do need to program all features and timers before you can automatically exit programming.

**#13:** Connect the **GREEN** or **BROWN** wire to a momentary or pulsed source. Connect the **BLUE** or **WHITE** wire to a device being controlled. Upon seeing a number of pulses within a number of seconds the first time, the outputs will latch. After seeing a number of pulses within a number of seconds the second time, the outputs will unlatch. You may program how many pulses the AXUTR needs to see to latch and unlatch the outputs.

**Example:** turn on and off your parking lights 4 times within 5 seconds to turn on aftermarket lights. Turn on and off 3 times within 5 seconds to turn the aftermarket lights off.

**#14:** Connect the **GREEN** or **BROWN** wire to a pulsed output source. Connect the **BLUE** or **WHITE** wire to a device being controlled. Upon seeing a user programmable number of pulses within a user programmable number of seconds, the **BLUE** and **WHITE** outputs will pulse once.

**Example:** if you programmed the AXUTR to see 4 pulses within 7 seconds, then for every 4 pulses the AXUTR sees within 7 seconds, the outputs will pulse once.

**#15:** Connect the **GREEN** or **BROWN** wire to a pulsed output source. Connect the **BLUE** or **WHITE** wire to a device being controlled. Upon a user programmable number of pulses the AXUTR sees within 5 (nonadjustable) seconds, the **BLUE** and **WHITE** outputs will turn on and delay for a user programmable time, then the outputs will turn off.

**#16:** Connect the **BROWN** or **GREEN** wire to a momentary source. Connect the **BLUE** or **WHITE** wire to the device being controlled. On the first pulse the AXUTR receives, the **WHITE** wire will latch on. On the second pulse the **WHITE** wire will unlatch and the **ORANGE** wire will latch on. On the third pulse, the **WHITE** and **ORANGE** wires will latch on. On the fourth pulse both the **WHITE** and **ORANGE** wire will turn off.

## Programming the AXUTR with a Feature Number

**Please READ! Many technical phone calls can be avoided by reading this section thoroughly.**

- In the instructions below, when asked to 'Pulse' the trigger wire, this will indicate to temporarily ground the **BROWN** wire to chassis ground and then ungrounding it. Each time you do this, the LED indicator will turn on and off.
  - All 'Feature Select' and 'Timer' section in the chart **MUST** be programmed from a left to right order. Even if you do not need all the outputs of the AXUTR, an option or time must be set for that wire(s) in order for the AXUTR to finish programming.
  - If you do not understand this written part of the instructions, you can use the flow chart on page 4. The flow chart will help you program the AXUTR step by
1. Select a feature you want from the chart and write down the Feature above. Slide the switch to the on position and apply 12-volt to the AXUTR **RED** wire. 'Pulse' the trigger wire the number of times of the selected Feature number. Wait 3 seconds, and the LED will flash the amount of times you 'Pulsed' the trigger wire saving that Feature number into memory. note: If you are doing Feature# 1 through 4, 8 or 16, you may go directly to step #4 after you do step #1.
  2. When selecting a feature, 'Pulse' the trigger wire once to select the 1st option, twice within 3 seconds to select the 2nd option, or 3 times within 3 seconds to select the third option.

**Example:** Feature# 9, 10, and 12 needs an option selected.

- **OR** - If you need to select how many pulses you need to trigger an event, 'Pulse' the wire the number of times needed.

**Example:** Feature# 7, 11, 13, 14, and 15 need a number of pulses to trigger an event.

After 3 seconds, the LED will flash the amount of times you 'Pulsed' the trigger wire telling what option you selected or how many pulses the AXUTR needs for

a triggered event. Repeat if other wires need to have an option selected. After all remaining options are programmed in the 'Feature Select' section, the AXUTR will automatically go to the 'Timer' section.

3. In the 'Timer' section in the chart, where a 'T' is indicated, you will need to program a time for that specific wire(s). If in the 'Feature Select' section you programmed for a pulse or latched event for that color wire, then the timer for that wire will be automatically skipped because the timer is not needed.

**To start programming the time needed, 'Pulse' the trigger wire one time to start the timer:**

**Minutes:** The LED will flash rapidly 1 time, indicating you need to program the number of minutes. 'Pulse' the trigger wire for the number of minutes needed. After 3 seconds the LED will flash the number of minutes recorded. If you program for 5 or greater, the AXUTR will default to 4 for minutes. If you need zero minutes, do nothing and wait the 3 seconds.

**Seconds in tens place:** The LED will flash rapidly 2 times indicating you need to program the number of seconds in the tens place. 'Pulse' the trigger wire the number of seconds needed. After 3 seconds the LED will flash the number of seconds recorded in the tens place. If you program for 6 or greater, the AXUTR will default to 5 for the tens place. If you need zero seconds in the tens place, do nothing and wait the 3 seconds.

**Seconds in ones place:** The LED will flash rapidly 3 times indicating you need to program the number of seconds in the ones place. 'Pulse' the trigger wire the number of seconds needed. After 3 seconds the LED will flash the number of seconds recorded in the ones place. If you program for 10 or greater, the AXUTR will default to 9 seconds for the ones place. If you need zero seconds in the ones place, do nothing and wait the 3 seconds.

*Continued on the next page*



## Installation instructions for part AXUTR



# Programming the AXUTR with a Feature Number *(Continued)*

**End of timer:** The LED will flash rapidly 4 times indicating that the timer is finish recording.

**Note:** Repeat step 3 if more than one timer has to be recorded, otherwise go to step 4.

**Example 1:** If you want 36 seconds for a timer, 'Pulse' the trigger wire one time. The LED will flash rapidly 1 time, wait 3 seconds and 0 minutes will be recorded. The LED will flash rapidly 2 times, 'Pulse' the trigger wire 3 times, after 3 seconds the LED will flash 3 times indicating 3 was recorded for the tens place. The LED will flash rapidly 3 times, 'Pulse' the trigger wire 6 times and after 3 seconds the LED will flash 6 times indicating 6 was recorded for the ones place.

**Example 2:** If you want 2 minutes and 25 seconds for a timer, 'Pulse' the trigger wire one time. The LED will flash rapidly 1 time, 'Pulse' the trigger wire 2 times, after 3 seconds the LED will flash 2 times, indicating 2 was recorded for the minutes place. The LED will flash rapidly 2 times, 'Pulse' the trigger wire 2 times, after 3 seconds the LED will flash 2 times indicating 2 was recorded for the tens place. The LED will flash rapidly three times, 'Pulse' the trigger wire 5 times, after 3 seconds the LED will flash 5 times indicating 5 was recorded for seconds in the ones place.

**Note:** *The maximum time that can be set is 4 minutes and 15 seconds. If you go beyond the maximum time, the AXUTR will automatically use 4 minutes and 15 seconds as a time. In Feature# 10, if you did not program for any timers, then the 'Timer' section will automatically be skipped.*

- After all options and/or timers are programmed; the LED will flash rapidly for 3 seconds, indicating that programming is finished. Slide the switch to the OFF position. If you make a mistake during programming, you will need to start over from step 1.
- Return to the previous section to finish wiring the AXUTR.

## IMPORTANT

If you are having difficulties with the installation of this product, please call our Tech Support line at **1-800-253-TECH**. Before doing so, look over the instructions a second time, and make sure the installation was performed exactly as the instructions are stated. Please have the vehicle apart and ready to perform troubleshooting steps before calling.



### KNOWLEDGE IS POWER

Enhance your installation and fabrication skills by enrolling in the most recognized and respected mobile electronics school in our industry. Log onto [www.installerinstitute.com](http://www.installerinstitute.com) or call 800-354-6782 for more information and take steps toward a better tomorrow.



**Metra recommends MECP  
certified technicians**