



## Harley Davidson **Electra Glide FHTP** **(Police Edition) 2014-Up**

Visit [MetraPowerSports.com](http://MetraPowerSports.com) for more detailed information about the product and up-to-date vehicle specific applications

### KIT FEATURES

- ISO DDIN radio provision †
- Axxess interface in water resistant enclosure included
- ASWC-1/AXSWC in water resistant enclosure included for installations adding OEM handlebar audio controls
- Antenna included



† Kit designed for "L" shaped aftermarket radio, with chassis at top

### KIT COMPONENTS

- A) Radio housing
- B) Radio brackets
- C) (4) Phillips screws
- D) (4) #10-32 x 1/2" Phillips steel machine screws
- E) Axxess interface and harness (not shown)
- F) ASWC-1/AXSWC interface (not shown)

**A**

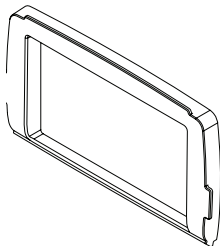

**B**

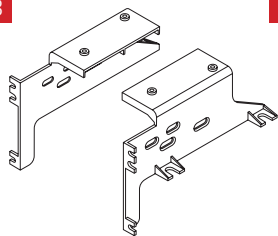

**C**



**D**

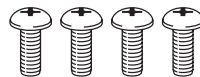

### TABLE OF CONTENTS

Fairing Disassembly.....	2-3
Kit Assembly .....	4
Final Assembly .....	7
Axxess Interface Installation.....	5-10

### WIRING & ANTENNA CONNECTIONS

Wiring Harness: Axxess interface and harness included  
Antenna: Included  
Steering wheel control interface: Included

### TOOLS REQUIRED

- Panel removal tool
- Phillips screwdriver
- Torx screwdriver
- Allen wrenches

**CAUTION!** All accessories, switches, climate controls panels, and especially air bag indicator lights must be connected before cycling the ignition. Also, do not remove the factory radio with the key in the on position, or while the vehicle is running.

## FAIRING DISASSEMBLY

1. Remove (4) T-27 Torx screws from the inner fairing. (Figure A)
2. Remove (3) T-27 Torx screws securing the windshield (caution not to drop the outer fairing or windshield). (Figure B)
3. Remove the outer fairing, unplugging the headlight. (Figure C)
4. Remove (2) T-27 Torx screws to remove the fairing vent, then remove the vent. (Figure D)

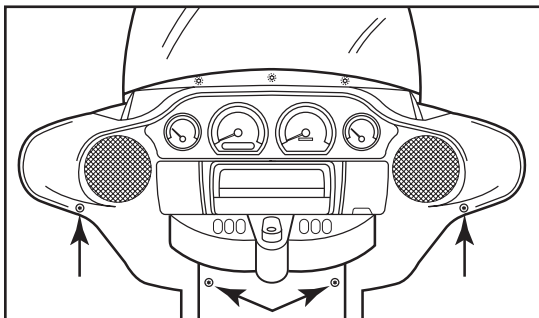

(Figure A)

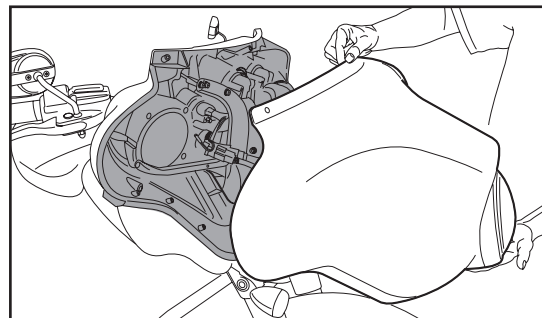

(Figure C)

*Continued on the next page*

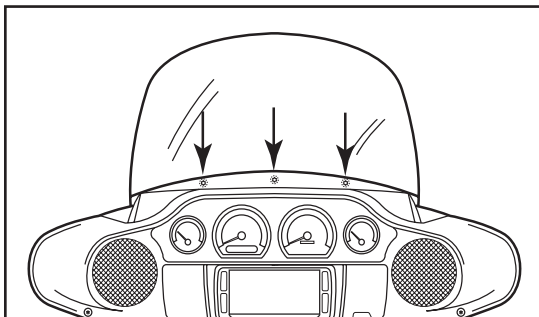

(Figure B)

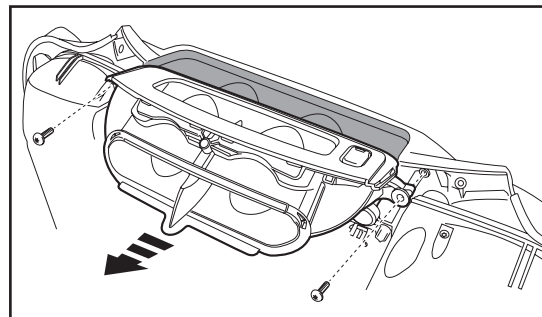

(Figure D)

## FAIRING DISASSEMBLY (CONT)

5. Remove (11) screws securing the radio “dummy” bracket: (Figure E)
  - a. (2) T-27 Torx screws shared with the gauge cluster and a third T-27 Torx screw to remove the gauge cluster in step 7.
  - b. (4) 5/32” Allen screws facing outward.
  - c. (4) T-25 Torx screws secured to the radio “dummy”.
  - d. (1) T-25 Torx screw shared with the storage pocket.
6. Remove the radio bracket. (Figure E)

**Note:** This bracket will be reused in Kit Assembly.
7. Remove the gauge cluster. (Figure E)
8. Remove (4) 3/16 Allen screws from the sides of the radio “dummy”. (Figure F)

**Note:** These screws will be reused in Kit Assembly.
9. Slide the radio “dummy” out and remove. Unplug the connector circled. (Figure F)

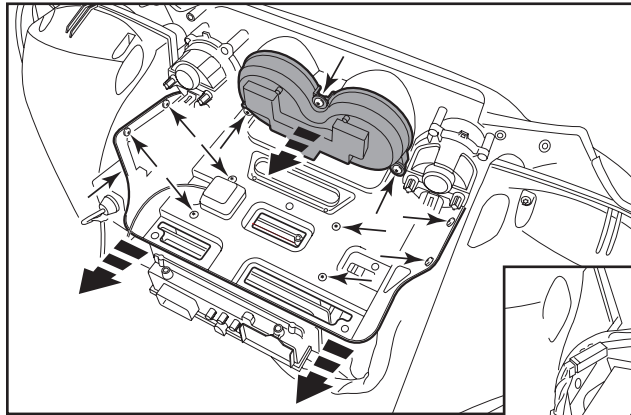

(Figure E)

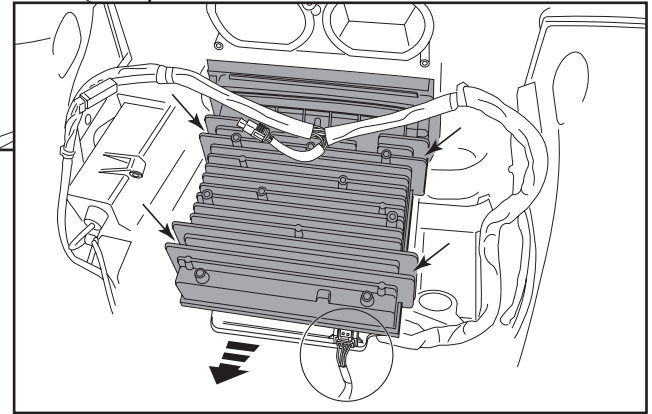

(Figure F)

## KIT ASSEMBLY

1. Secure the **radio brackets** to the **radio housing** using (4) Phillips screws provided. (Figure A)
2. Slide the radio into the radio housing assembly and secure using screws supplied with the radio. (Figure B)
3. Secure the radio assembly to the bike using (4) 3/16 Allen screws removed in Fairing Disassembly, step 8. (Figure C)
4. Attach the radio bracket removed in Fairing Disassembly, step 6, to the top of the radio assembly. Secure with (4) #10-32 x 1/2" Phillips steel machine screws supplied.

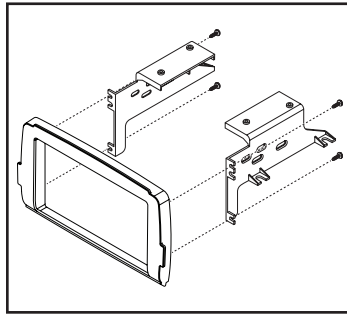

(Figure A)

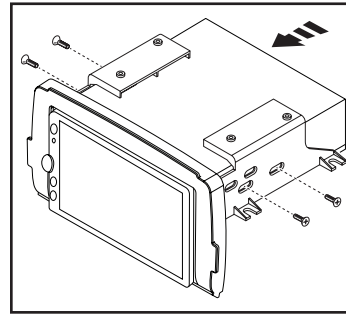

(Figure B)

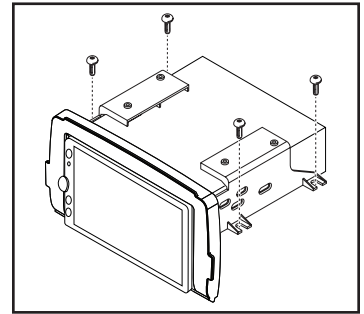

(Figure C)

*Continue to Axxess Interface Installation*

# AXXESS INTERFACE INSTALLATION

## INTERFACE FEATURES

---

- Includes a T-harness for tapping into the CAN data system
- Includes a harness with OEM connectors for adding front & rear OEM speakers
- Provides accessory power (10-amp)
- Includes an ASWC-1/AXSWC (handlebar audio control interface) for installations adding OEM handlebar audio controls
- Water resistant enclosures with zip tie mounts for both the Axxess interface & ASWC-1/AXSWC
- Micro-B USB updatable

## INTERFACE COMPONENTS

---

- Axxess Interface:
  - Circuit board
  - Housing, cap, and cover
  - Harness
- ASWC-1/AXSWC Interface:
  - Circuit board
  - Housing, cap, and cover
  - Harness
  - 3.5mm adapter
- BC-9700P wire harness

## TABLE OF CONTENTS

---

Pre-wiring Instructions .....	6
Wiring Instructions.....	6
Installation .....	7
Programming.....	7
Final Assembly.....	7
Handlebar Control Settings.....	8-10
Updating.....	10

## TOOLS & INSTALLATION ACCESSORIES REQUIRED

---

- Crimping tool and connectors, or solder gun, solder, and heat shrink
- Tape • Wire cutter • Zip ties

## PRE-WIRING INSTRUCTIONS

### BC-DDPPAK interface water resistant enclosure installation

- Push the **harness** into the **cap**.
- Connect the **harness** to the **circuit board**, then clip it onto the circuit board enclosure.
- The AXSWC interface and enclosure will only be used when OEM handlebar audio controls have been installed. If used, follow these same instructions, after Programming.

### BC-9700WP wire harness installation

- Locate the harness unplugged in Fairing Disassembly. Connect the (2) 4-pin harnesses in between to "T" into the factory wiring.
- Route the power harness to the battery, then connect the positive and negative wires.
- Route the front speaker harnesses to the OEM speakers. The connector with **Gray** wires goes to the brake side; **White** goes to the clutch side. †
- The connector with **Green & Purple** wires will be used for adding rear OEM speakers. †

† The OEM connector can be cut off to use aftermarket speakers. Black stripe wires are negative, solid are positive.

## WIRING INSTRUCTIONS

### From the BC-DDPPAK harness to the aftermarket radio, connect the:

- **Black** wire to the ground wire.
- **Yellow** wire to the battery wire.
- **Red** wire to the accessory wire.
- **Orange** wire to the illumination wire.

## WIRING INSTRUCTIONS (CONT)

- **Gray** wire to the right front positive speaker output.
- **Gray/Black** wire to the right front negative speaker output.
- **White** wire to the left front positive speaker output.
- **White/Black** wire to the left front negative speaker output.
- **Purple** wire to the right rear positive speaker output.
- **Purple/Black** wire to the right rear negative output.
- **Green** wire to the left rear positive speaker output.
- **Green/Black** wire to the left rear negative speaker output.

### 3.5mm jack - handlebar control retention:

- **For Parrot radios:** Follow the AX-SWC-PARROT (sold separately) instructions.
- **For radios with a wire for SWC:** Connect the 3.5mm adapter to the 3.5mm jack, then connect:
  - **Brown** to the radio wire labeled: Key-A, SWC-1, or SWCIR
  - **Brown/White** to the radio wire labeled: Key-B or SWC-2 (if applicable)
- **Note:** After programming, assign SWC buttons in radio settings.
- **Note:** XITE radios require SWC-2 to Brown.
- **For all other radios:** Connect the 3.5mm jack to the steering wheel control input.

## INSTALLATION

### With the key in the off position:

1. Connect the **BC-DDPPAK harness** to the **BC-9700P wire harness** previously installed.
2. Install the antenna provided with the kit and complete all necessary connections to the radio.

**Attention!** To prevent error codes, all electronic devices including the headlight and turn signals must be connected before proceeding to the next step.

## PROGRAMMING

**Attention!** If the interface loses power for any reason, the following steps will need to be performed again.

1. Cycle the ignition on and wait until the radio comes on.  
**Note:** If the radio doesn't come on within 60 seconds, turn the key to the off position, disconnect the interface, check all connections, reconnect the interface, and then try again.
2. Test the radio for proper operation.
3. Cycle the engine off.

## PROGRAMMING (CONT)

### For installation when OEM handlebar audio controls have been installed:

4. Install the ASWC-1/AXSWC and enclosure as per Pre-Wiring Instructions:
  - a. Cycle the ignition on, the LED will start flashing rapidly.  
**Note:** If the LED didn't flash rapidly, press the reset button for 3 seconds.
  - b. Tap the Volume Up button on the handlebar at a moderate pace until the LED stops flashing rapidly.
  - c. After a few seconds the LED should stop flashing rapidly, then go out for approximately 2 seconds.
  - d. After approximately 2 seconds there will be a series of 7 **Green** flashes, (6) short, and (1) long. The (1) long flash represents that the AXSWC detected the bike.
  - e. The LED will pause for another 2 seconds, then flash **Red** up to (23) times depending on which radio is connected to the interface. Refer to the LED feedback section for information.
  - f. This is the end of the auto detection stage. If the ASWC-1/AXSWC detected the radio and vehicle successfully, the LED will light up solid.
  - g. Test the handlebar controls for proper operation. Refer to "Handlebar Control Settings" before proceeding onto the next step.

## FINAL ASSEMBLY

1. Reassemble the fairing in reverse order of disassembly.

# HANDLEBAR CONTROL SETTINGS

## L.E.D. Feedback

The (23) Red L.E.D. flashes represent which brand radio the ASWC-1/AXSWC is connected to. Each flash represents a different radio manufacturer. For example, if you are installing a JVC radio, the ASWC-1/AXSWC will flash Red (5) times, and then stop. Following is a legend that dictates which radio manufacturer corresponds to which flash.

## L.E.D. Feedback Legend

1 flash - Eclipse (Type 1) †	9 flashes - Valor	16 flashes - Philips
2 flashes - Kenwood ‡	10 flashes - Clarion (Type 2) †	17 flashes - TBD
3 flashes - Clarion (Type 1) †	11 flashes - Metra OE	18 flashes - JBL
4 flashes - Sony / Dual	12 flashes - Eclipse (Type 2) †	19 flashes - Insource Audio
5 flashes - JVC	13 flashes - LG	20 flashes - Magnadyne
6 flashes - Pioneer / Jensen	14 flashes - Parrot **	21 flashes - Boss (Type 3)
7 flashes - Alpine *	15 flashes - XITE	22 flashes - Axxera
8 flashes - Visteon		23 flashes - Axxera (w/ IR wire)

\* **Note:** If the ASWC-1/AXSWC flashes Red (7) times, and you do not have an Alpine radio connected to it, that means the ASWC-1/AXSWC does not detect a radio connected to it. Verify that the 3.5mm jack is connected to the correct steering wheel jack/wire in the radio.

\*\* **Note:** The AX-SWC-PARROT is required (sold separately). Also, the Parrot radio must be updated to rev. 2.1.4 or higher through [www.parrot.com](http://www.parrot.com).

† **Note:** If you have a Clarion radio and the handlebar controls do not work, change the radio type to the other Clarion radio type; same for Eclipse. The following section explains how to do this.

‡ **Note:** If you have a Kenwood radio and the L.E.D. feedback comes back as showing as a JVC radio, change the radio type to a Kenwood. The following section explains how to do this.

**Attention:** The Axxess Updater App can also be used to program the following (3) sub-sections as well, pending that the interface has been initialized and programmed.

## Radio Type

If the L.E.D. flashes do not match the radio that is connected, change the radio type.

1. After (3) seconds of turning the key on, press and hold the Volume-Down button on the handlebar until the L.E.D. in the ASWC-1/AXSWC goes solid.
2. Release the Volume-Down button; the L.E.D. will go out indicating we are now in Changing Radio Type mode.
3. Refer to the Radio Legend to know which radio number you would like to have programmed.
4. Press and hold the Volume-Up button until the L.E.D. goes solid, and then release. Repeat this step for the desired radio number.
5. Once the desired radio number has been selected, press and hold the Volume-Down button on the handlebar until the L.E.D. goes solid. The L.E.D. will remain on for about (3) seconds while it stores the new radio information.
6. Once the L.E.D. goes off, the Radio Type mode will then end. You can now test the handlebar controls.

**Note:** If at any time the user fails to press any button for a period longer than ten seconds, this process will abort.



## HANDLEBAR CONTROL SETTINGS (CONT)

### Radio Legend

1 - Eclipse (Type 1)	7 - Alpine	13 - LG	19 - Insanse Audio
2 - Kenwood	8 - Visteon	14 - Parrot	20 - Magnadyne
3 - Clarion (Type 1)	9 - Valor	15 - XITE	21 - Boss (Type 3)
4 - Sony / Dual	10 - Clarion (Type 2)	16 - Philips	22 - Axxera
5 - JVC	11 - Metra OE	17 - TBD	23 - Axxera (w/ IR wire)
6 - Pioneer/Jensen	12 - Eclipse (Type 2)	18 - JBL	

### Remap Buttons

The interface has the ability to change the button assignment for the handlebar control buttons, except Volume-Up and Volume-Down. Follow the steps below to remap the handlebar control buttons.

1. Within the first twenty seconds of turning the ignition on, press and hold the Volume-Up button on the handlebar until the L.E.D. goes solid.
2. Release the Volume-Up button, the L.E.D. will then go out; The Volume-Up button has now been programmed.
3. Follow the list in the Button Assignment Legend to reference the order in which the handlebar control buttons need to be programmed.

**Note:** If the next function on the list is not present on the handlebar, press the Volume-Up button for (1) second until the L.E.D. comes on, and then release the Volume-Up button. This will tell the ASWC-1/AXSWC that this function is not available, and it will move on to the next function.

4. To complete the remapping process, press and hold the Volume-Up button on the handlebar until the L.E.D. in the ASWC-1/AXSWC goes out.

### Button Assignment Legend

1 - Not allowed	10 - Band
2 - Not allowed	11 - Play/Enter
3 - Seek-Up/Next	12 - PTT (push to talk)
4 - Seek-Down/Prev	13 - On-Hook
5 - Mode	14 - Off-Hook
6 - Mute	15 - Fan-Up *
7 - Preset-Up	16 - Fan-Down *
8 - Preset-Down	17 - Temp-Up *
9 - Power	18 - Temp-Down *

#### **\* Not applicable in this application**

**Note:** The aftermarket radio may not have all of these commands. Please refer to the manual provided with the radio, or contact the radio manufacturer, for specific commands recognized by that particular radio.

## HANDLEBAR CONTROL SETTINGS (CONT)

### Dual Assignment (long button press)

The ASWC-1/AXSWC has the capability to assign two functions to a single button, except Volume-Up and Volume-Down. Follow the steps below to program the button(s) to your liking.

**Note:** *Seek-Up and Seek-Down come programmed as Preset-Up and Preset-Down for a long button press.*

1. Turn on the ignition but do not start the vehicle.
2. Press and hold down the handlebar control button that you want to assign a long press function to, for ten seconds, or until the L.E.D. flashes rapidly. At this point release the button; the L.E.D. will then go solid.
3. Press and release the Volume-Up button the number of times corresponding to the new button number selected. Refer to the Dual Assignment Legend. The L.E.D. will flash rapidly while the Volume-Up button is being pressed, and then go back to a solid L.E.D. once released. Go to the next step once the Volume-Up button has been pressed the desired number of times.

**Caution:** *If more than ten seconds elapses between pressing the Volume-Up button, this process will abort, and the L.E.D. will go out.*

4. To store the long press button in memory, press the button that you assigned a long press button to (the button held down in Step 2). The L.E.D. will now go off indicating the new information has been stored.

**Note:** *These steps must be repeated for each button you would like to assign a dual purpose feature to. To reset a button back to its default state, repeat Step 1, and then press the Volume-Down button. The L.E.D. will go off, and the long press mapping for that button will be erased.*

### Dual assignment legend

- |                    |                  |
|--------------------|------------------|
| 1 - Not allowed    | 10 - Band        |
| 2 - Not allowed    | 11 - Play/Enter  |
| 3 - Seek-Up/Next   | 12 - PTT         |
| 4 - Seek-Down/Prev | 13 - On-Hook     |
| 5 - Mode/Source    | 14 - Off-Hook    |
| 6 - ATT/Mute       | 15 - Fan-Up      |
| 7 - Preset-Up      | 16 - Fan-Down *  |
| 8 - Preset-Down    | 17 - Temp-Up *   |
| 9 - Power          | 18 - Temp-Down * |

**\* Not applicable in this application**

## UPDATING

- Download and install the Axxess Updater from [axxessinterfaces.com](http://axxessinterfaces.com).
- Connect the USB-MINI-CAB update cable (sold separately) between the Axxess interface and the computer.
- From the Start Menu of the computer, click on on “All Programs”, then “Axxess Updater”.
- Press “Update Firmware” on both pages. The software will begin to download at this point.

**Note:** Please note which firmware downloaded to the interface. This will help in troubleshooting, if need be.





# BC-DDPPAK

INSTALLATION INSTRUCTIONS



Having difficulties? We're here to help.



Contact our Tech Support line at:

**386-257-1187**



Or via email at:

[techsupport@metra-autosound.com](mailto:techsupport@metra-autosound.com)

### Tech Support Hours (Eastern Standard Time)

Monday - Friday: 9:00 AM - 7:00 PM

Saturday: 10:00 AM - 7:00 PM

Sunday: 10:00 AM - 4:00 PM



### **KNOWLEDGE IS POWER**

Enhance your installation and fabrication skills by enrolling in the most recognized and respected mobile electronics school in our industry. Log onto [www.installerinstitute.com](http://www.installerinstitute.com) or call 800-354-6782 for more information and take steps toward a better tomorrow.



**Metra recommends MECP certified technicians**