



Shown with optional BC-SPG Grilles

Part Applications

- Harley Davidson FLHT, FLHTCU, FLHTCUL, FLHX, FLHXS, FLTRX, FLTRXS, FLTRXSE (w/ lower fairings) 2014-Up (†)
- (†) Does not fit Twin-Cooled® models
- (†) FLHX models require purchase of lower fairing kit

Part Components

A) Speaker enclosure (L & R)



B) Enclosure tray (L & R), (4) #14 x 1 SS philips screws



C) BC-SPG Speaker Grilles (*Sold separately)



Harley-Davidson® 2014-up*

Lower Fairing Audio Upgrade Kit

Visit MetraPowerSports.com for more detailed information about the product and up-to-date vehicle specific applications.

Note: This instruction sheet references service manual information. Service manual for year/model motorcycle is required for this installation. This Installation will reuse hardware from the existing mounted lower fairing.

Product Features

- Sound-optimized enclosure for improved bass performance
- Molded tray fits snugly into lower fairings
- OE Fit and finish
- Painted a complimentary Matte Black finish

TABLE OF CONTENTS

| | |
|--------------------------|-----|
| Preparation..... | 2 |
| Fairing Disassembly..... | 3-4 |
| Installation..... | 5-8 |

TOOLS & INSTALLATION ACCESSORIES REQUIRED

- Torx® Drivers T-10, T-15, T-20, T-25
- Phillips screwdriver
- Socket wrenches, 7/16, 1/2.
- 3/8 Drill bit
- Blue Thread-locker
- *Silicone (3MSCLR), gasket tape (IBSPKGTP)
- *(2) 3/8 wire grommet
- Masking tape
- *Optional

Attention! We recommend removing the main battery fuse prior to installation. When testing the after-market equipment, ensure that all factory equipment is connected before cycling the key to ignition.

PREPARATION

Attention! This instruction manual references service manual information. A service manual for this year/model motorcycle is required for this installation. One is available from a Harley-Davidson dealer.

Attention! To prevent accidental vehicle start-up, which could cause death or serious injury, remove main fuse before proceeding.

1. Open left side saddle bag lid.
2. Rotate (2) mounting studs counter clockwise until released, then lift off saddle bag
3. Remove left side access cover.
4. **For vehicles equipped with security siren:** Verify that the Hands-Free Fob is present.
5. Cycle the key to the ignition position.
6. Remove main fuse.

(Figure A)

Models Equipped With Fairing Lower

1. Open lower fairing glove box door.
2. Remove 7/16 in. nut securing the lower fairing cap.
(Figure B.1)
3. Remove fairing cap.
(Figure B.2)
4. Remove lower fairing clamp screw and 1/2 in. nut.
(Figure B.3)
5. Remove (2) 7/16 in. flange nuts securing upper clamp, then remove fairing assembly.
(Figure B.4)

Continue to disassembly

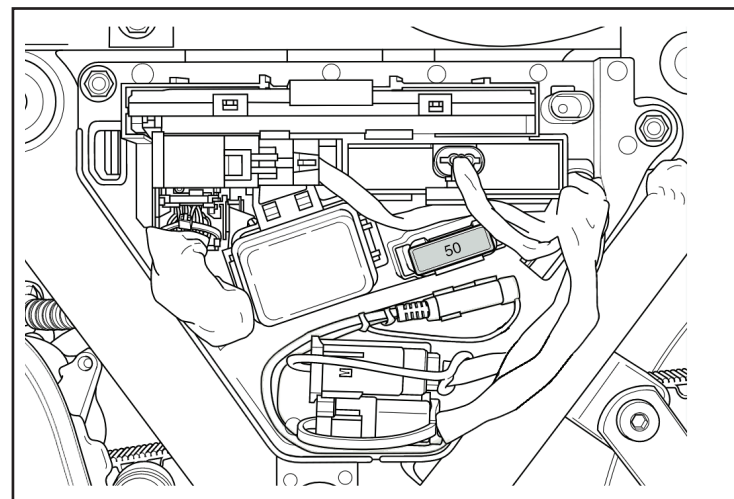

(Figure A)

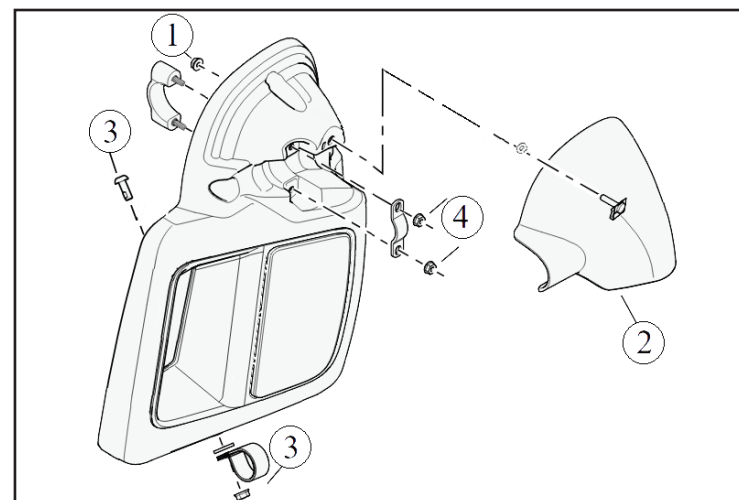

(Figure B)

FAIRING DISASSEMBLY

Speaker Pod

1. From the front, remove the (2) screws , block-off panel then glove box.(Figure A.1,2,4)
***Attention:** Take precautions not to break off the lock positioning tab.
(Figure A.3)
2. Disconnect the vent door linkage and separate assembly from fairing.
(Figure B.1)

Lower Fairings

1. From the back, remove the (3) screws.
(Figure C.1)

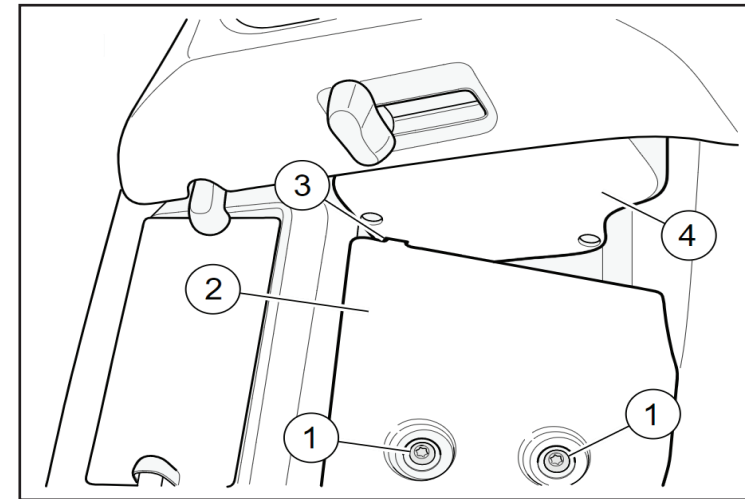

(Figure A)

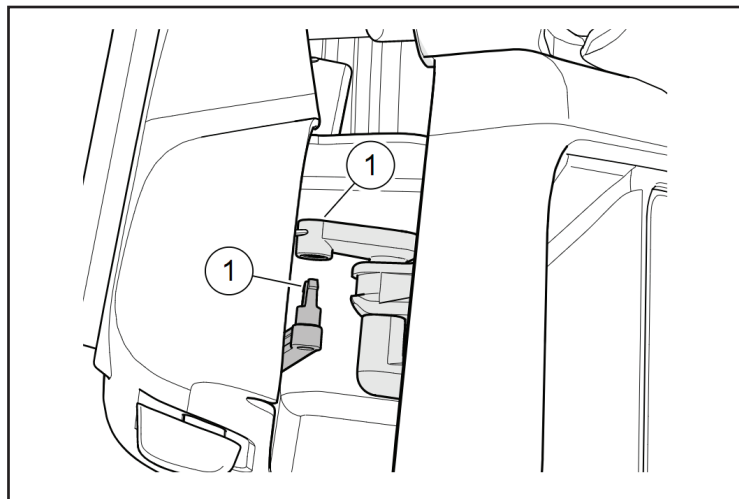

(Figure B)

Continued on next page

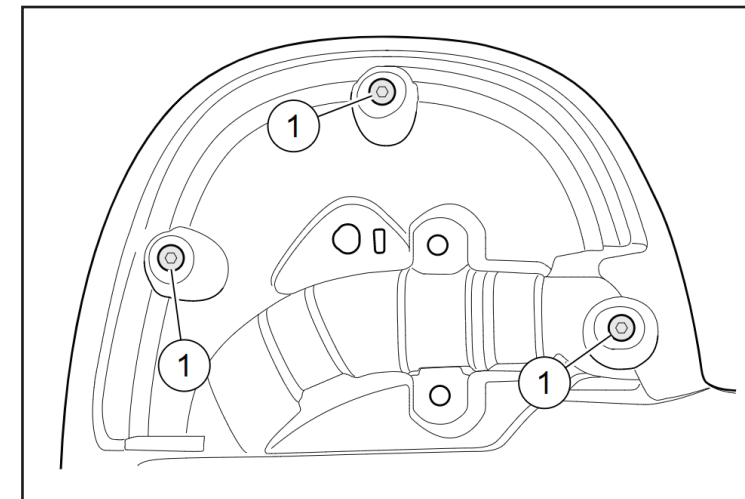

(Figure C)

FAIRING DISASSEMBLY

Speaker / Glove Box housing

1. If equipped, remove the (3) glove box screws.
(Figure A.1)
2. Remove glove box tray.
(Figure A.2)
3. Remove the linkage screw.
(Figure B.1)
4. Separate linkage assembly.
(Figure B.2, B.3)

***Note:** Retain the original linkage assembly and vent control for re-install on the BC-HDLFPP if the original parts are desired.
(Figure A.3, B.2, B.3)

Continue to installation

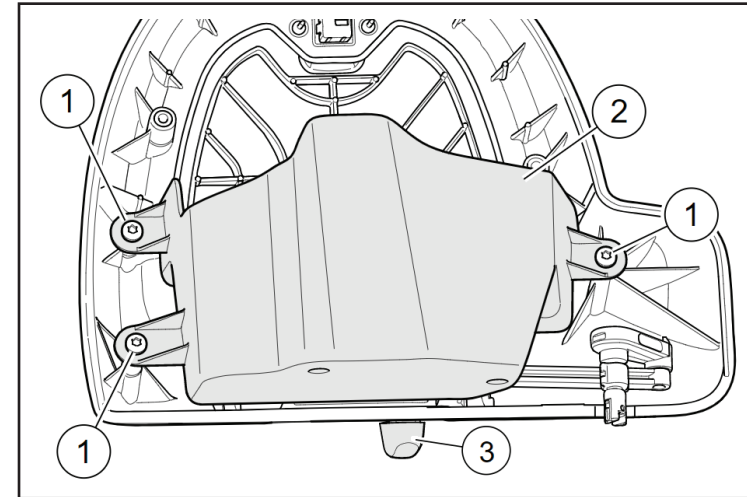

(Figure A)

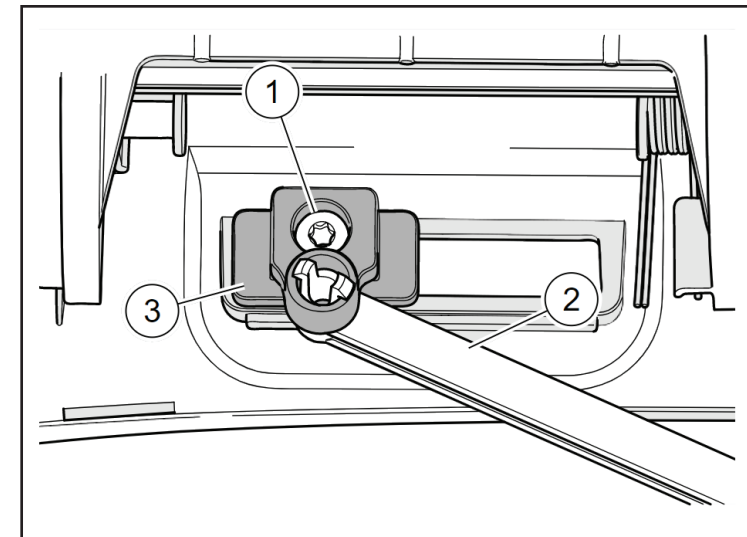

(Figure B)

INSTALLATION

Speaker Pod and Tray

Tip: To ease assembly, first install then remove the (5) screws in the enclosure without the tray.

1. ***Optional:** To maximize performance apply silicone (3MSCLR) to the tray mating surface. (Figure A.1)
2. Assemble the speaker enclosure to the tray. (Figure B.1)
***Note:** If you do not apply silicone, make sure to install (2) #14 X 3/4" Philips head screws to securely hold the tray in place. (Figure B.3)
3. ***Optional:** to maximize performance apply gasket tape (IBSPKGTP) to the tray mating surface. (Figure B.5)

Continue to final assembly

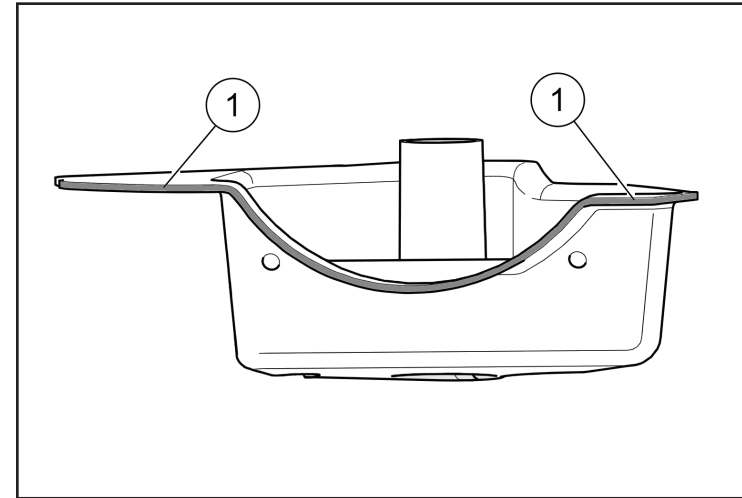

(Figure A)

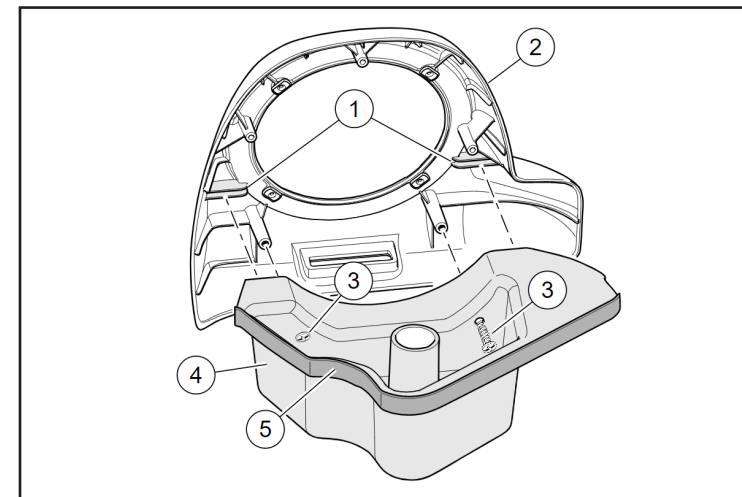

(Figure B)

INSTALLATION

Speaker Enclosure / Tray

1. Optional: Reattach the screw and the linkage onto the new enclosure front. Tighten the screw to 1.3–2 N·m (12–18 in-lbs).
2. Position the enclosure assembly and connect the linkage. (Figure A.1)
3. Once the linkage is connected, from the rear, re-install (3) coarse thread screws. (Figure B.1)
4. Tighten the screws to 1.3–2 N·m (12–18 in-lbs)

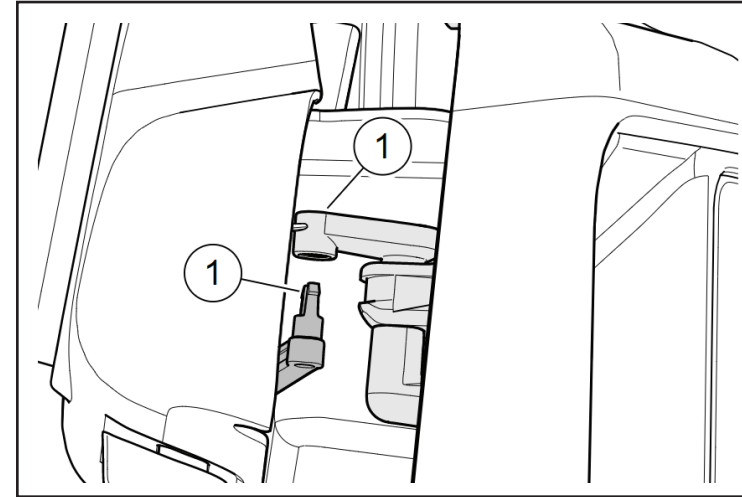

(Figure A)

Continued on next page

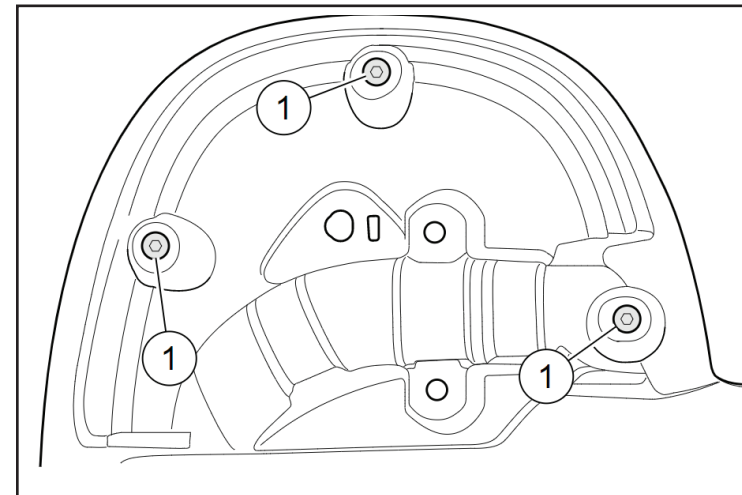

(Figure B)

INSTALLATION

Speaker Enclosure / Tray

1. ***Optional:** To prevent unwanted rattle or vibration; fold a piece of gasket tape over the locating tab from the block-off panel.
(Figure A.1)
2. Install the block-off panel.
(Figure A.2)
3. Apply thread locker to the threads of the (2) screws then install the screws and tighten to 7.3–8.4 N·m (65–75 in-lbs).
(Figure A.3)
4. On the back side of the fairing, measure about 25 mm (1.0 in) over and 9.5 mm ($\frac{3}{8}$ in) up from the lower fairing cap mating flange.
(Figure B.1)
5. Mark the location to drill the hole. Cover the drill point with masking tape to prevent cracking or chipping of the paint. Drill a 9.5 mm ($\frac{3}{8}$ in) hole in the glove box inboard side wall.
(Figure B.2)
***Optional:** Insert a rubber grommet to protect the speaker wires.
6. **Install the lower fairing:** leave the lower fairing cap off.
7. Route the speaker wires through the hole in the lower fairing.
8. Route the wiring harness under the fairing up to the radio and connect to either radio (without amp) or amplifier (with amp).
9. Secure wire harness and verify wiring does not interfere with steering or suspension travel.
10. Install the lower fairing cap.
11. Connect the speaker wires to the speaker.
12. Install the speaker then grille cover.

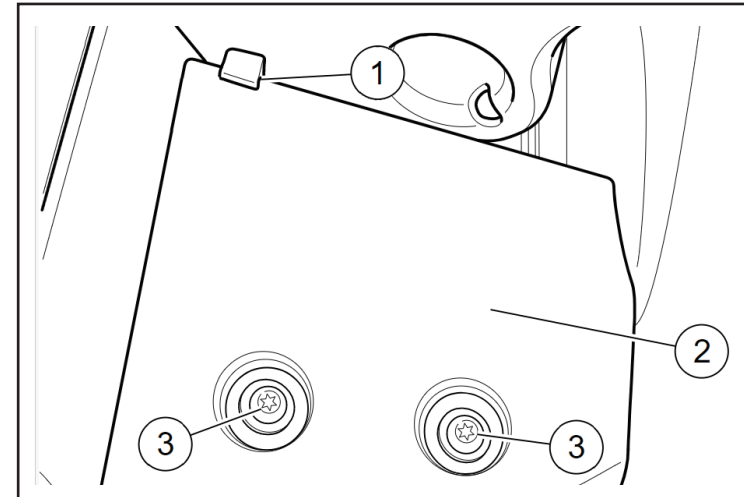

(Figure A)

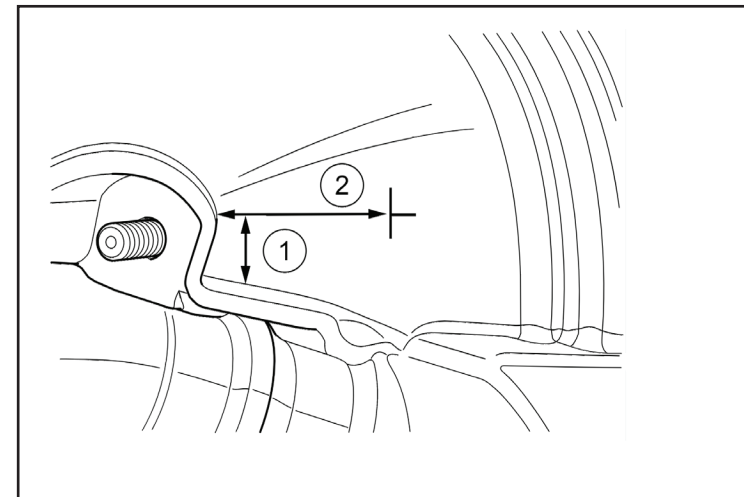

(Figure B)

Continued on next page



INSTALLATION

BC-HDLFPP

INSTALLATION INSTRUCTIONS

#MetraPowerSports



NOTE:

To prevent possible damage to the sound system, verify that the ignition key switch is in the OFF position before installing the main fuse.

1. See the service manual and install the main fuse.
2. Test the sound system for proper operation.
3. See the service manual. Install the outer fairing and windshield.

WARNING:

- Be sure that steering is smooth and free without interference
- Interference with steering could result in loss of vehicle control and death or serious injury
- Be sure that wires, harnesses or lines do not pull tight when handlebars are turned fully to left or right fork stops
- Verify that steering is smooth and clear from stop to stop

Tip!: Install a AX-DSPX-HD2-WR sound processor to optimize the performance and sound response of the Saddle Tramp BC-HDLFPP

NOTE:

If objectionable vibration occurs due to high levels of bass response, additional foam may be inserted between block-off panels and fairing lowers.

Having difficulties? We're here to help.



Contact our Tech Support line at:
386-257-1187



Or via email at:
techsupport@metra-autosound.com

Tech Support Hours (Eastern Standard Time)

Monday - Friday: 9:00 AM - 7:00 PM

Saturday: 10:00 AM - 7:00 PM

Sunday: 10:00 AM - 4:00 PM



KNOWLEDGE IS POWER

Enhance your installation and fabrication skills by enrolling in the most recognized and respected mobile electronics school in our industry. Log onto www.installerinstitute.com or call 800-354-6782 for more information and take steps toward a better tomorrow.



Metra Recommends MECP
certified technicians