



Harley-Davidson Electra Glide FLHTP (Police Edition) 2014-Up

Visit MetraOnline.com for more detailed information about the product and up-to-date vehicle specific applications

KIT FEATURES

- ISO DDIN radio provision*
- Saddle Tramp interface with built in handlebar controls
- Water resistant enclosure for added protection
- Antenna adapter included

*This kit can only be used with an ISO DDIN radio that has an "L" shaped chassis design.



KIT COMPONENTS

- A) Radio housing • B) Radio brackets • C) #8 x 3/8" Phillips screws (4) • D) #10-32 x 1/2" Phillips steel machine screws (4) • E) Handlebar Control interface (not shown)

A

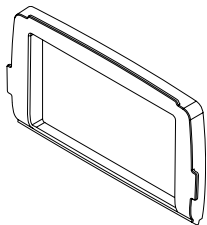

B

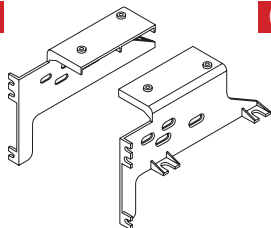

C



D

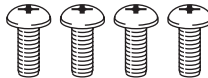

TABLE OF CONTENTS

Fairing Disassembly	
Harley Davidson Electra Glide Police package 2014-Up	2-3
Kit Assembly	4
Saddle Tramp Interface Installation	5-9

WIRING & ANTENNA CONNECTIONS (Included)

- Saddle Tramp harness
- Antenna Adapter
- Handlebar Control interface

TOOLS REQUIRED FOR KIT INSTALLATION

- Panel removal tool • Phillips screwdriver
- Torx screwdrivers • Allen wrenches

ATTENTION: With the key out of the ignition, disconnect the negative battery terminal before installing this product. Ensure that all installation connections are secure before cycling the ignition to test this product.
NOTE: Refer also to the instructions included with the aftermarket radio.

FAIRING DISASSEMBLY

Harley Davidson Electra Glide Police package 2014-Up

1. Remove (4) T-27 Torx screws from the inner fairing. (Figure A)
2. With a firm grip on the windshield, remove (3) T-27 Torx screws, and then remove the windshield. (Figure B)
Note: The outer fairing will also be loosened.
3. Remove the outer fairing, unplugging the headlight. (Figure C)
4. Remove (2) T-27 Torx screws to remove the fairing vent, and then remove the vent. (Figure D)

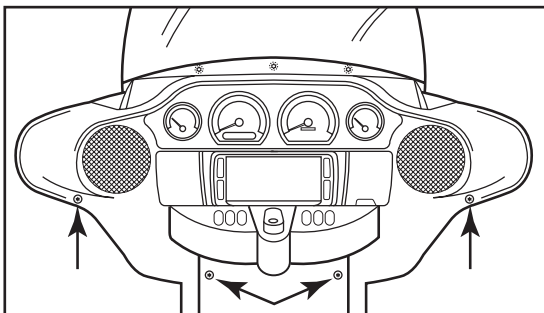

(Figure A)

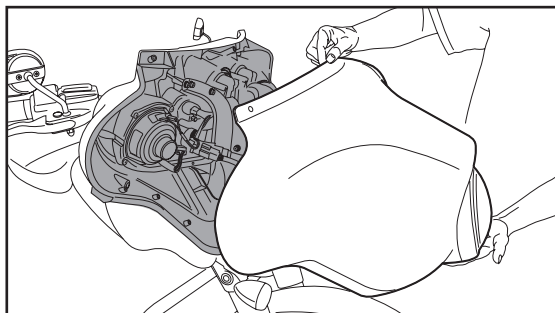

(Figure C)

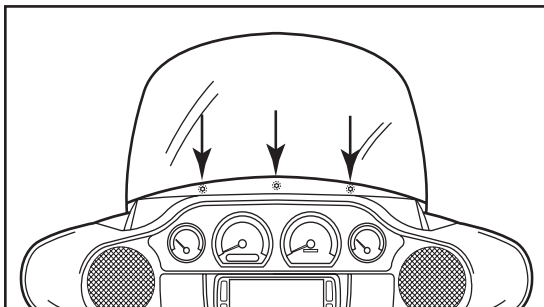

(Figure B)

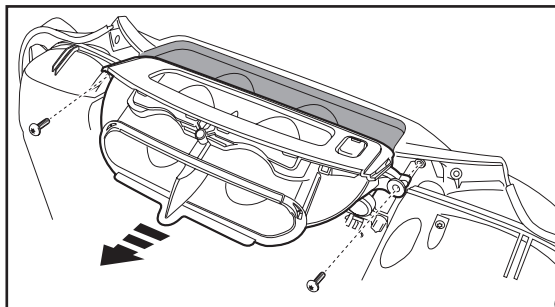

(Figure D)

Continued on next page

FAIRING DISASSEMBLY *(CONT)*

5. Remove (11) screws securing the radio “dummy” bracket: (Figure E)
 - a. (2) T-27 Torx screws shared with the gauge cluster and a third T-27 Torx screw to remove the gauge cluster in step 7.
 - b. (4) 5/32" Allen screws facing outward.
 - c. (4) T-25 Torx screws secured to the radio “dummy”.
 - d. (1) T-25 Torx screw shared with the storage pocket.
6. Remove the radio bracket. (Figure E)
Note: This bracket will be reused with the kit assembly.
7. Remove the gauge cluster. (Figure E)
8. Remove (4) 3/16 Allen screws from the sides of radio. (Figure F)
Note: These screws will be reused with the kit assembly.
9. Slide the radio out toward the rear of the bike, disconnect the wiring, and then remove the radio. (Figure F)

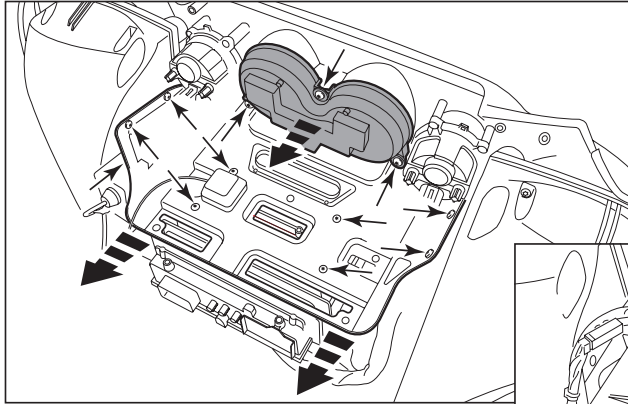

(Figure E)

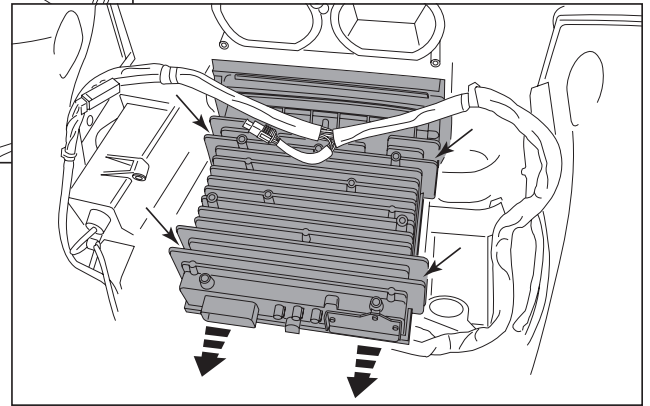

(Figure F)

KIT ASSEMBLY

1. Secure the **radio brackets** to the **radio housing** with (4) #8 x 3/8" Phillips screws provided in this kit. (Figure A)
2. Slide the aftermarket radio into the radio housing assembly and secure with screws supplied with the radio. (Figure B)
3. Secure the radio housing assembly to the bike using (4) 3/16" Allen screws previously removed in step 8 of disassembly. (Figure C)
4. **For the Electra Glide FLHTP 2014-Up:**
Attach the radio bracket removed in step 6 of disassembly to the top of the radio housing assembly, and secure with (4) #10-32 x 1/2" Phillips steel machine screws provided in this kit.

Continue to BC-HDR-K2 Interface Installation

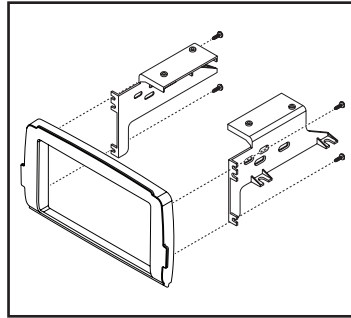

(Figure A)

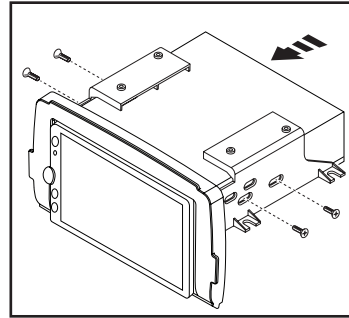

(Figure B)

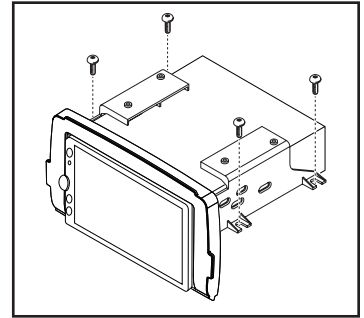

(Figure C)

SADDLE TRAMP INTERFACE INSTALLATION

INTERFACE FEATURES

- Includes a T-harness for tapping into the CAN data system
- Includes a harness with OEM connectors for adding front & rear OEM speakers
- Provides accessory power (10-amp)
- Retains handlebar controls:
 - H-D Handlebar controls can be added
 - 71500248C '14-'20 w/o Traction Control
 - 71500561 '20-Up w/Traction Control
- Water resistant enclosures with zip-tie mounts
- USB Micro-B updatable

INTERFACE COMPONENTS

- Saddle Tramp Interface:
 - Circuit board
 - Housing, cap, and cover
 - Harness
 - 3.5mm adapter

TABLE OF CONTENTS

Saddle Tramp Interface Installation	5
Wire Harness Installation	6
Connections	7
Programming	8
Troubleshooting	9

TOOLS REQUIRED TO MAKE ELECTRICAL CONNECTIONS

- Cutting tool • Crimping tool • Tape
- Connectors (example: butt-connectors, bell caps, etc.)

IMPORTANT NOTE

Caution - If the fuse on the aftermarket radio exceeds 10 amps you *MUST* run a fused wire from your vehicle's battery to avoid potential damage.

WIRE HARNESS INSTALLATION

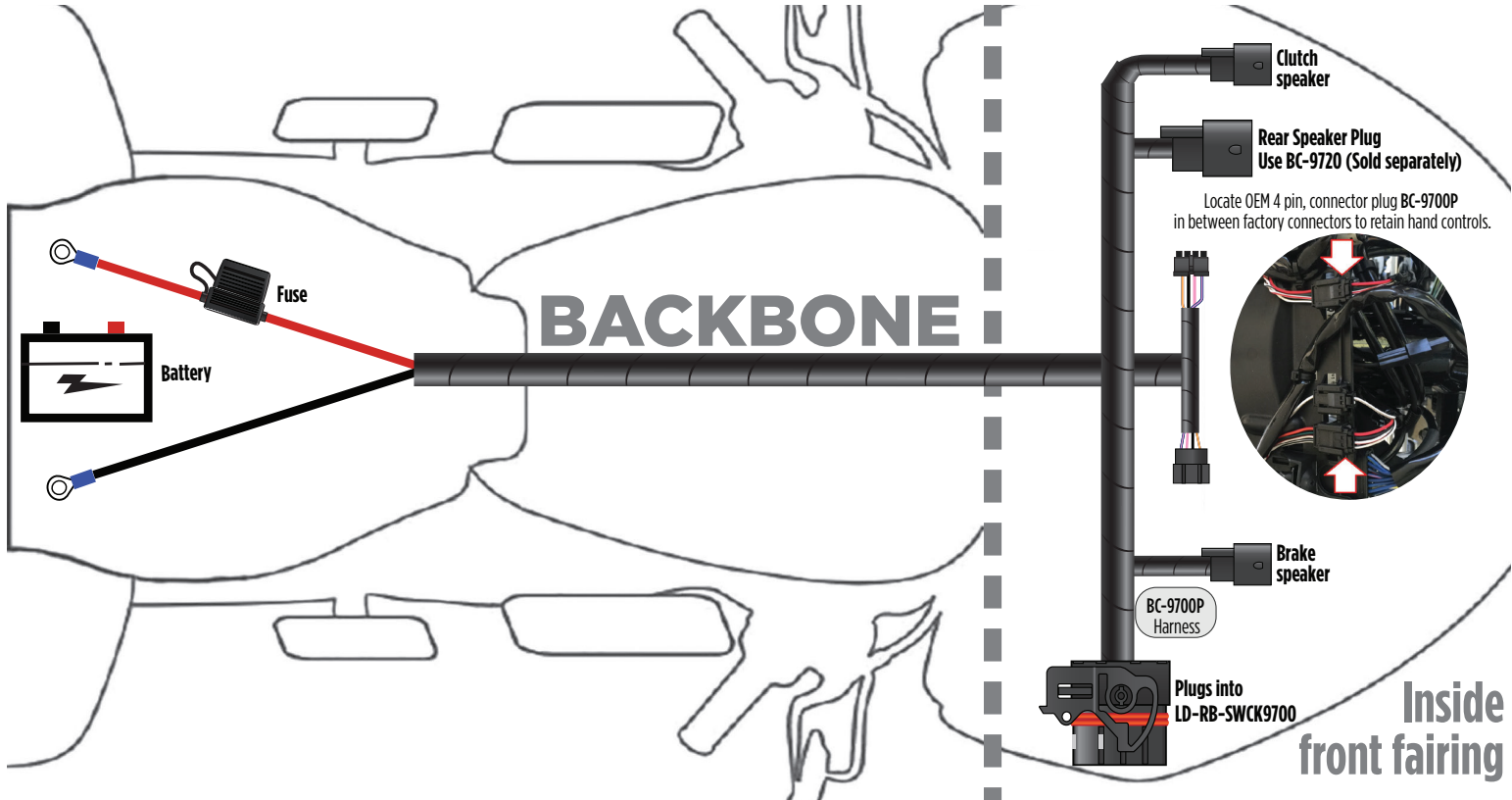

CONNECTIONS

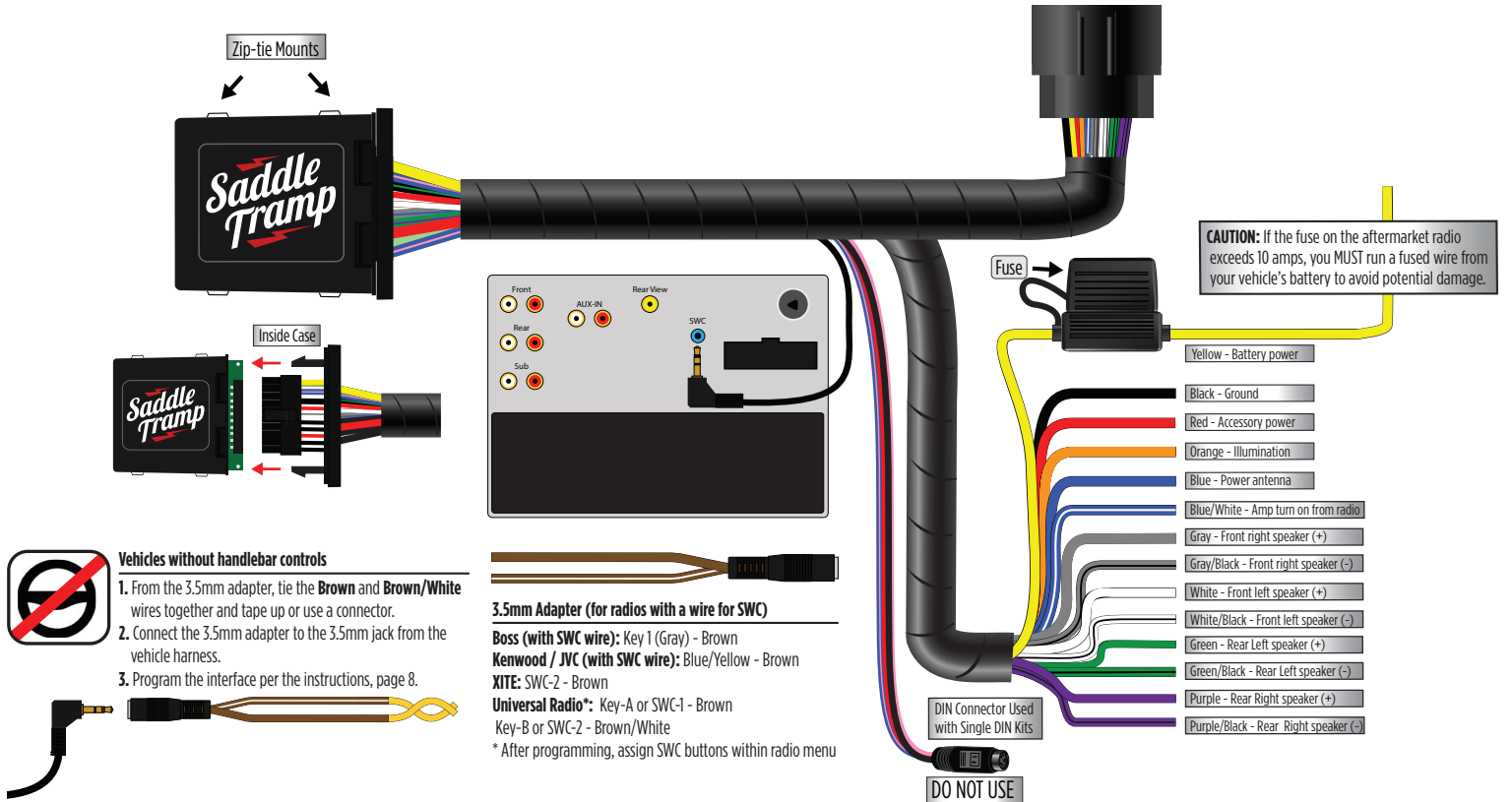

Vehicles without handlebar controls

1. From the 3.5mm adapter, tie the **Brown** and **Brown/White** wires together and tape up or use a connector.
2. Connect the 3.5mm adapter to the 3.5mm jack from the vehicle harness.
3. Program the interface per the instructions, page 8.

PROGRAMMING



1. Turn the ignition on.



2. Connect the **BC-HDR-K2 harness** to the wiring harness in the bike.



3. **For vehicles without hand controls:** The interface will automatically program.



4. **For vehicles with hand controls:** Locate the **Volume Up** button on the clutch side hand control. Program the interface by tapping the **Volume Up** button at a heartbeat pace until the LED light stops flashing.

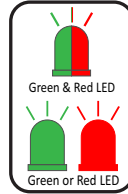

5. The LED light will flash **Green & Red** while the interface programs the radio to the handlebar controls. Once programmed, the LED light will go out, then produce a pattern which will identify the radio type installed.

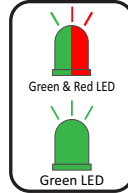

6. The LED light will go out, then once again quickly flash **Green & Red** while the interface programs itself to the vehicle. Once programmed, the LED light will go out again, then turn solid **Green**.

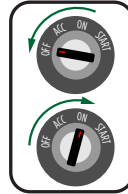

7. Turn the ignition off, then back on.



8. Test all functions of the installation for proper operation.

TROUBLESHOOTING

1.

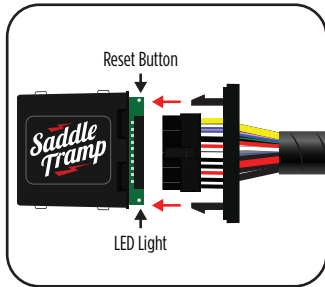

If the interface fails to function you will need to press the reset button. To access the button remove the cover of the water resistant case, slide out the circuit board and press the reset button. The LED will start flashing, starting at step 2, repeat the programing process.

2. **Final LED Feedback**

At the end of programming the LED light will turn **Solid Green** which indicates programming was successful. If the LED light didn't turn **Solid Green**, reference the list below to understand which programming section the problem may stem from.

LED Light	Radio Programming Section	Vehicle Programming Section
Solid Green	Pass	Pass
Slow Red Flash	Fail	Pass
Slow Green Flash	Pass	Fail
Solid Red	Fail	Fail

Note: If the LED light shows **Solid Green** for **Pass** (indicating everything programmed correctly), yet the steering wheel controls don't work, check to ensure that the 3.5mm jack is plugged in, and also plugged into the correct jack on the radio. Once corrected, press the reset button, then program again.





Having difficulties? We're here to help.



Contact our Tech Support line at:

386-257-1187



Or via email at:

techsupport@metra-autosound.com

Tech Support Hours (Eastern Standard Time)

Monday - Friday: 9:00 AM - 7:00 PM

Saturday: 10:00 AM - 7:00 PM

Sunday: 10:00 AM - 4:00 PM



KNOWLEDGE IS POWER

Enhance your installation and fabrication skills by enrolling in the most recognized and respected mobile electronics school in our industry. Log onto www.installerinstitute.edu or call 386-672-5771 for more information and take steps toward a better tomorrow.



**Metra recommends MECP
certified technicians**