



### Harley-Davidson **Street Glide, Electra Glide, Ultra, and Limited Models 2014-Up†** **Road Glide 2015-Up†**

† Non-amplified models only

Visit [MetraOnline.com](http://MetraOnline.com) for more detailed information about the product and up-to-date vehicle specific applications

#### KIT FEATURES

- ISO DIN radio provision
- Saddle Tramp interface with built in handlebar controls
- Water resistant enclosure for added protection
- Antenna adapter included

#### KIT COMPONENTS

- A) Radio housing • B) Radio brackets • C) LCD screen • D) LCD back plate • E) #8 x 3/8" Phillips screws (6) • F) #10-32 1/2" Phillips steel machine screws (4)

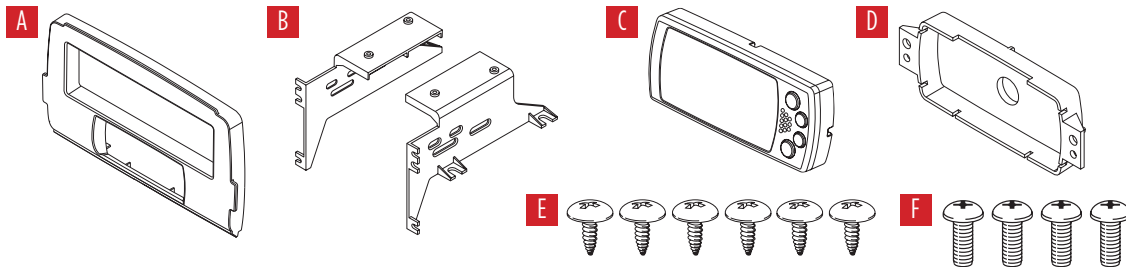

#### TABLE OF CONTENTS

Fairing Disassembly	
Harley Davidson Street Glide, Electra Glide, Ultra, and Limited models 2014-up	2-3
Harley Davidson Road Glide 2015-up	4
Kit Assembly	5
Saddle Tramp Interface Installation	6-10

#### WIRING & ANTENNA CONNECTIONS (Included)

- Wiring Harness: Saddle Tramp interface and harness  
Antenna Adapter  
Handlebar Control interface

#### TOOLS REQUIRED FOR KIT INSTALLATION

- Panel removal tool • Phillips screwdriver
- Torx screwdrivers • Allen wrenches

**ATTENTION:** With the key out of the ignition, disconnect the negative battery terminal before installing this product. Ensure that all installation connections are secure before cycling the ignition to test this product.  
**NOTE:** Refer also to the instructions included with the aftermarket radio.

## FAIRING DISASSEMBLY

### Harley Davidson Street Glide, Electra Glide, Ultra, and Limited models 2014-up

1. Remove (4) T-27 Torx screws from the inner fairing. (Figure A)
2. With a firm grip on the windshield, remove (3) T-27 Torx screws, and then remove the windshield. (Figure B)  
**Note:** The outer fairing will also be loosened.
3. Remove the outer fairing, unplugging the headlight. (Figure C)
4. Remove (2) T-27 Torx screws to remove the fairing vent, and then remove the vent. (Figure D)

Continued on next page

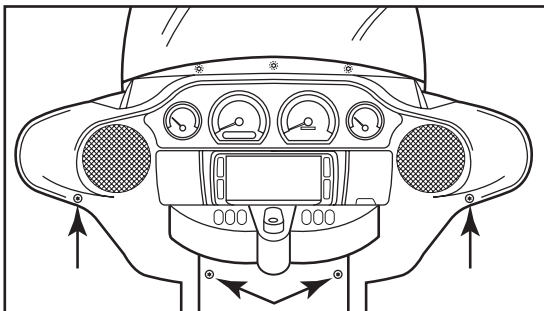

(Figure A)

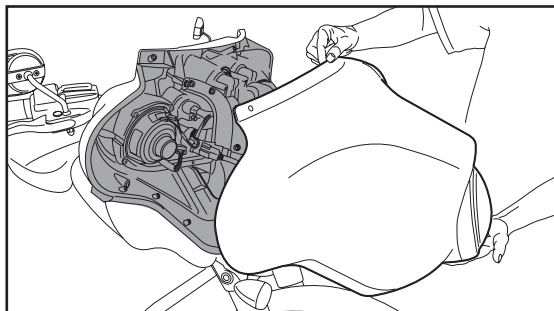

(Figure C)

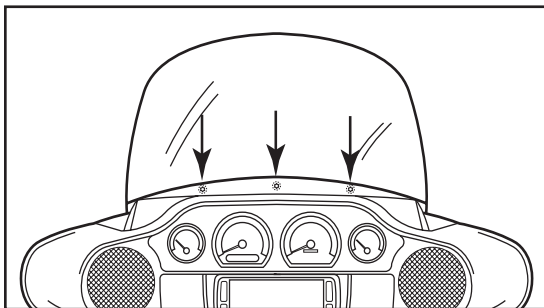

(Figure B)

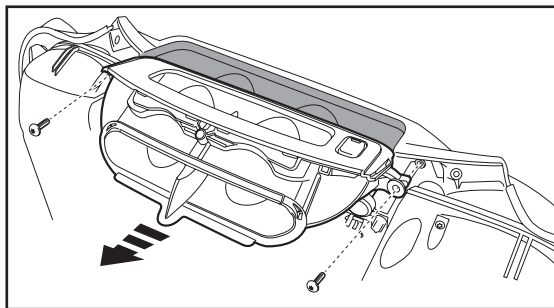

(Figure D)

## FAIRING DISASSEMBLY (CONT)

5. Remove (11) screws securing the radio “dummy” bracket: (Figure E)
  - a. (2) T-27 Torx screws shared with the gauge cluster and a third T-27 Torx screw to remove the gauge cluster in step 7.
  - b. (4) 5/32" Allen screws facing outward.
  - c. (4) T-25 Torx screws secured to the radio “dummy”.
  - d. (1) T-25 Torx screw shared with the storage pocket.
6. Remove the radio bracket. (Figure E)  
**Note:** This bracket will be reused with the kit assembly.
7. Remove the gauge cluster. (Figure E)
8. Remove (4) 3/16" Allen screws from the sides of radio. (Figure F)  
**Note:** These screws will be reused with the kit assembly.
9. Slide the radio out toward the rear of the bike, disconnect the wiring, and then remove the radio. (Figure F)

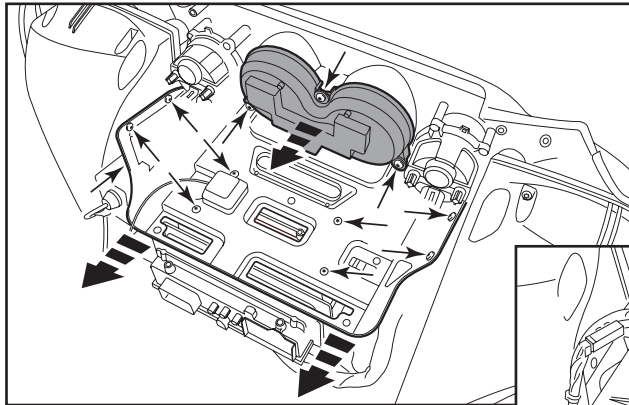

(Figure E)

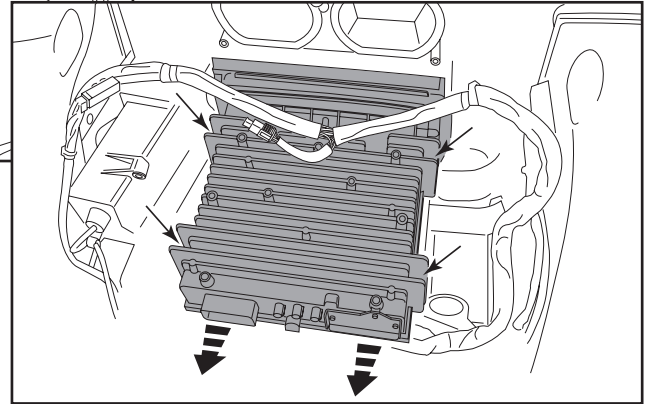

(Figure F)

Continue to Kit Assembly

## FAIRING DISASSEMBLY (CONT)

### Harley Davidson Road Glide 2015-up

1. Remove the lower torx screws on either side holding the wind deflector wings. (Figure A)  
**Note:** Only the lower two need to be removed.
2. Remove (1) 3/16" Allen screw from each of the turn signals. (Figure B)
3. Remove (4) Phillips screws from the windshield and set the windshield aside. (Figure C)
4. Remove the top fairing trim clipped to the top of the radio. (Figure D)
5. Unplug the turn signals.

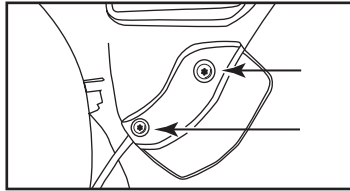

(Figure A)

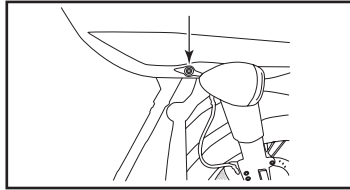

(Figure B)

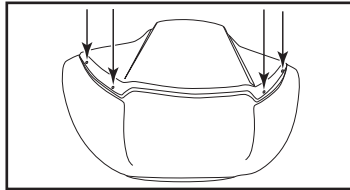

(Figure C)

6. Remove the speaker grills with a panel removal tool and remove (1) Torx screw from each side. (Figure E)  
**CAUTION:** The fairing will be loose at this point. Have a helper hold it to keep from damaging it when removing the screws.
7. Remove the fairing and set aside.
8. Remove (4) 3/16" Allen screws from the sides of the factory radio.  
**Note:** These screws will be reused in the BC-HDR-K3 kit assembly.  
**CAUTION:** Be sure to hold the radio when removing the last screw so it does not drop.
9. Unplug and remove the radio.
10. Remove (2) Torx screws securing the fairing bracket attached to the radio.  
**Note:** This bracket will be reused in the BC-HDR-K3 kit assembly. Please note the orientation of the bracket. The curved portion faces the rear of the bike.

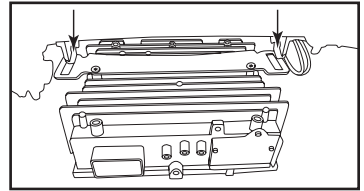

(Figure D)

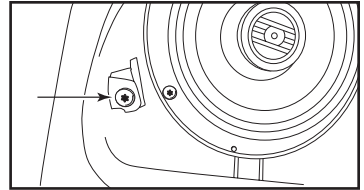

(Figure E)

Continue to Kit Assembly

## KIT ASSEMBLY

1. Secure the **radio brackets** to the **radio housing** with (4) #8 x 3/8" Phillips screws provided in this kit. (Figure A)
2. Slide the aftermarket radio into the radio housing assembly and secure with screws supplied with the radio. (Figure B)
3. Secure the radio housing assembly to the bike using (4) 3/16" Allen screws previously removed in step 8 of disassembly. (Figure C)

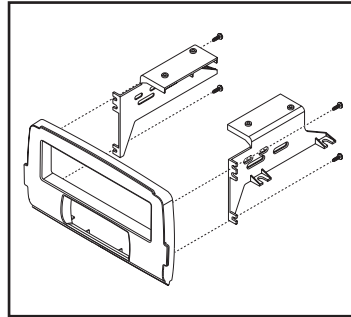

(Figure A)

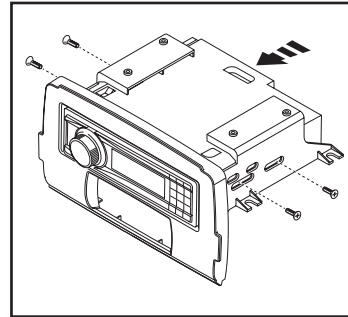

(Figure B)

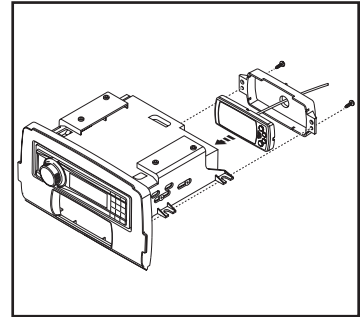

(Figure C)

*Continue to BC-HDR-K3 Interface Installation*

# SADDLE TRAMP INTERFACE INSTALLATION

## INTERFACE FEATURES

---

- Provides accessory power (12-volt 10-amp)
- Retains balance
- Retains handlebar controls
  - H-D Handlebar controls can be added
    - 71500248C '14-'20 w/o Traction Control
    - 71500561 '20-Up w/Traction Control
- USB Micro-B updatable

## INTERFACE COMPONENTS

---

- Saddle Tramp Interface:
  - Circuit board
  - Housing, cap, and cover
  - Harness
  - 3.5mm adapter

## TABLE OF CONTENTS

---

Installation .....	6
Connections.....	7
Programming.....	8
LCD Operation.....	9
Troubleshooting.....	10

## TOOLS REQUIRED TO MAKE ELECTRICAL CONNECTIONS

---

- Cutting tool • Crimping tool • Tape
- Connectors (example: butt-connectors, bell caps, etc.)

### IMPORTANT NOTE

*Caution - If the fuse on the aftermarket radio exceeds 10 amps you MUST run a fused wire from your vehicle's battery to avoid potential damage.*

# CONNECTIONS

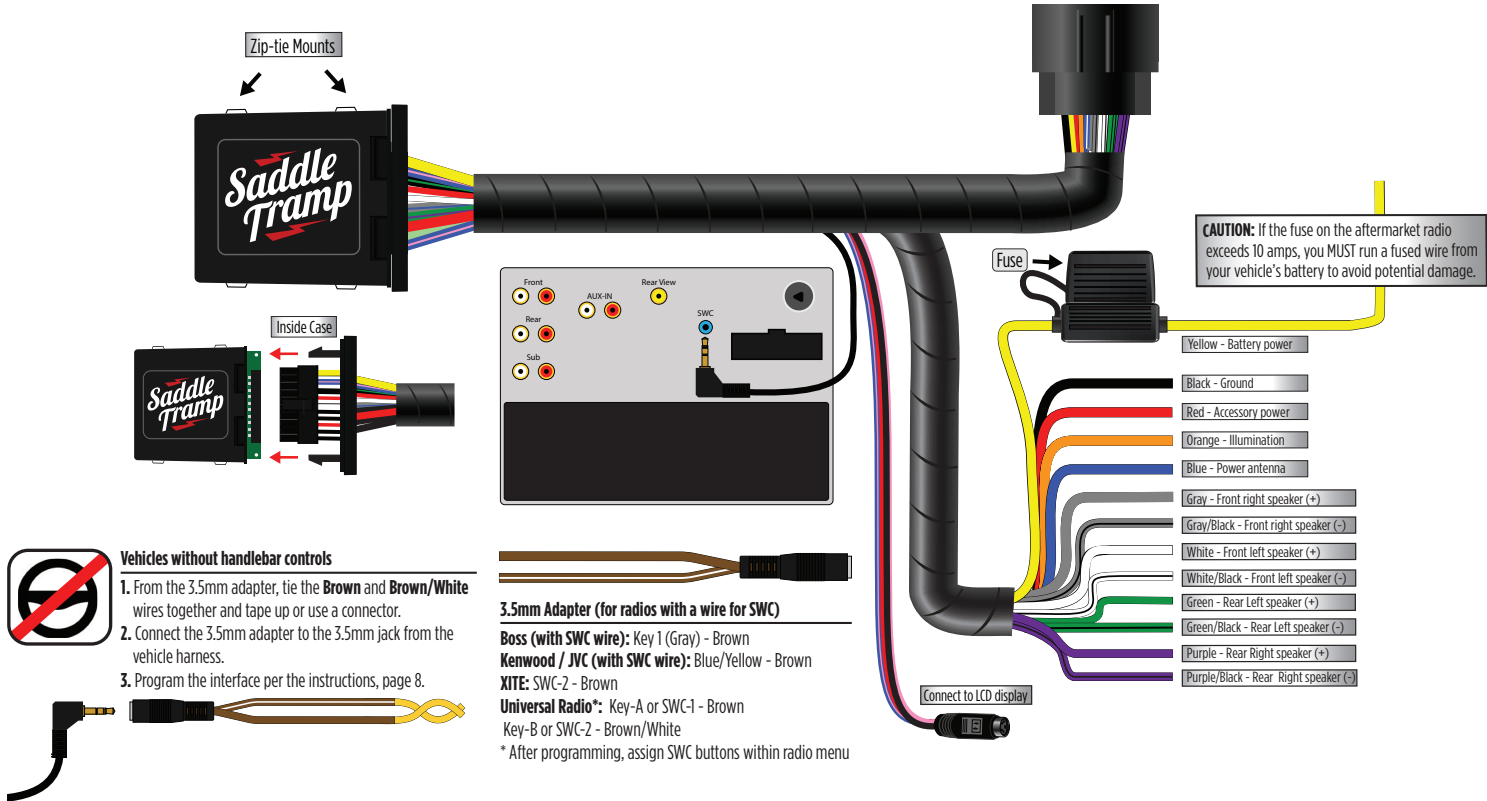

# PROGRAMMING



1. Turn the ignition on.



2. Connect the **BC-HDR-K3 harness** to the wiring harness in the bike.



3. **For vehicles without hand controls:** The interface will automatically program.



4. **For vehicles with hand controls:** Locate the **Volume Up** button on the clutch side hand control. Program the interface by tapping the **Volume Up** button at a heartbeat pace until the LED light stops flashing.

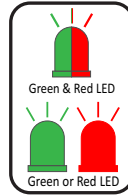

5. The LED light will flash **Green & Red** while the interface programs the radio to the handlebar controls. Once programmed, the LED light will go out, then produce a pattern which will identify the radio type installed.

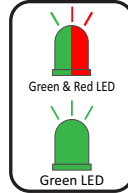

6. The LED light will go out, then once again quickly flash **Green & Red** while the interface programs itself to the vehicle. Once programmed, the LED light will go out again, then turn solid **Green**.

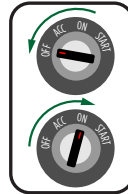

7. Turn the ignition off, then back on.



8. Test all functions of the installation for proper operation.



## LCD OPERATION

The included LCD screen provides oil pressure and EITMS status. For more information, please see the owner's manual that came with the bike.

### Main menu options:

- **Red** adjusts the red backlighting of the LCD (ranges from 1 to 32).
- **Blue** adjusts the blue backlighting of the LCD (ranges from 1 to 32).
- **Green** adjusts the green backlighting of the LCD (ranges from 1 to 32).
- **Contrast** adjusts the contrast of the LCD (ranges from 1 to 100).
- **Reset** puts the color back to the default settings.

▲ **Arrow Up** - Toggles “up” through menu options

▼ **Arrow Down** - Toggles “down” through menu options

↻ **Return/ESC** - Return to the previous menu

✓ **Enter** - Enter current menu option

## IMPORTANT NOTE

### If the Oil/EITMS information does not show up on the kit, perform this step;

- Press and hold the “Return/ESC” button on the LCD screen for 5 seconds until “Select Interface” comes up.
- Select “Connection Type”, and then press “Enter”.
- Scroll up or down to “Direct Connect”, and then press “Enter”.
- Once done, press “Return/ESC” to back out of that mode.

## TROUBLESHOOTING

1.

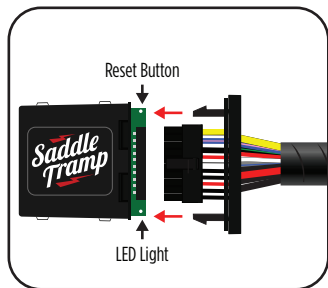

If the interface fails to function you will need to press the reset button. To access the button remove the cover of the water resistant case, slide out the circuit board and press the reset button. The LED will start flashing, starting at step 2, repeat the programming process.

2. **Final LED Feedback**

At the end of programming the LED light will turn **Solid Green** which indicates programming was successful. If the LED light didn't turn **Solid Green**, reference the list below to understand which programming section the problem may stem from.

LED Light	Radio Programming Section	Vehicle Programming Section
Solid Green	Pass	Pass
Slow Red Flash	Fail	Pass
Slow Green Flash	Pass	Fail
Solid Red	Fail	Fail

**Note:** If the LED light shows **Solid Green** for **Pass** (indicating everything programmed correctly), yet the steering wheel controls don't work, check to ensure that the 3.5mm jack is plugged in, and also plugged into the correct jack on the radio. Once corrected, press the reset button, then program again.



Having difficulties? We're here to help.



Contact our Tech Support line at:

**386-257-1187**



Or via email at:

[techsupport@metra-autosound.com](mailto:techsupport@metra-autosound.com)

### Tech Support Hours (Eastern Standard Time)

Monday - Friday: 9:00 AM - 7:00 PM

Saturday: 10:00 AM - 7:00 PM

Sunday: 10:00 AM - 4:00 PM



### **KNOWLEDGE IS POWER**

Enhance your installation and fabrication skills by enrolling in the most recognized and respected mobile electronics school in our industry. Log onto [www.installerinstitute.edu](http://www.installerinstitute.edu) or call 386-672-5771 for more information and take steps toward a better tomorrow.



**Metra recommends MECP  
certified technicians**